

Hydrogen Permeability and Integrity of Hydrogen Delivery Pipelines

Z. Feng*, S. Babu*, J.G. Blencoe*, L.M. Anovitz*,
M.L. Santella*, S.A. David*, and P. S. Korinko**

* Oak Ridge National Laboratory

* Savannah River National Laboratory

May 25, 2005

PD33

This presentation does not contain any proprietary or confidential information

OAK RIDGE NATIONAL LABORATORY
U. S. DEPARTMENT OF ENERGY

Overview

Timeline

- Project start date: March 2004
- Project end date: Sept 2005 (expected to continue in FY06)
- Percent complete: 60%

Budget

- Total project funding
 - DOE share: \$350,000
 - Contractor share: N/A
- FY04 Funding: \$150,000
- FY05 Funding: \$200,000

Barriers Addressed

- Hydrogen embrittlement and integrity of pipelines
 - Hydrogen embrittlement under high hydrogen gas pressure
 - Effects of welding
 - Hydrogen leakage

Partners

- Oak Ridge National Laboratory
- Savannah River National Laboratory

Partners and Collaborators

- Savannah River National Laboratory
 - Low pressure permeation test
- Edison Welding Institute
 - Pipeline materials
- Lincoln Electric Company
 - Welding electrode and weld materials for pipelines
- Trans Canada
 - Commercial welding of pipelines and industry expectations
- DOE Pipeline Working Group and Tech Team activities
 - FRP Hydrogen Pipelines
 - Materials Solutions for Hydrogen Delivery in Pipelines
 - Natural Gas Pipelines for Hydrogen Use

Project Objectives

- To gain basic understanding of hydrogen permeation behavior (absorption, diffusion, trapping, etc.) and its impacts on hydrogen embrittlement of pipeline steels under high gaseous pressures relevant to hydrogen gas transmission pipeline
- To develop technical basis and guidelines to ensure structural integrity and safety of H₂ pipelines

Approach

- High-pressure H₂ permeation and mechanical tests using ORNL's unique internally heated pressure vessel (IHPV)
 - Hydrogen permeation (solubility and diffusivity) and embrittlement behavior as function of pressure and temperature
 - Effects of steel composition and microstructure, and surface condition (including coating)
 - Effects of welding: weld microstructure, residual stress, and geometrical discontinuities
 - A database for common pipeline steels
- A risk assessment based approach to ensure the integrity and safety of H₂ pipelines
 - Hydrogen management
 - Microstructure management
 - Stress management
- Application of modern, hydrogen-cracking resistance, high-strength pipeline steels for hydrogen delivery and storage

Pipeline steels X52 and X65 and a weld metal with high-aluminum content were selected for current research

- API Grade X52 steel - 1950 production
 - 20 inch dia - 0.312 inch thick
 - Fe-0.3C-1.16Mn (wt.%)
- API Grade X65 steel - 1990 production
 - 16 inch dia - 0.500 inch thick
 - Fe-0.18C-1.36Mn (wt.%)
- Weld metal
 - Self-Shielded Flux Cored Arc Weld
 - Fe-0.22C-0.53Mn-1.77Al (wt.%)



Development of high-pressure H₂ testing apparatus

- ORNL has a internally-heated pressure vessel (IHPV) commissioned for high-pressure gaseous hydrogen experiments
- This vessel is upgraded for the proposed high-pressure hydrogen permeation and mechanical testing

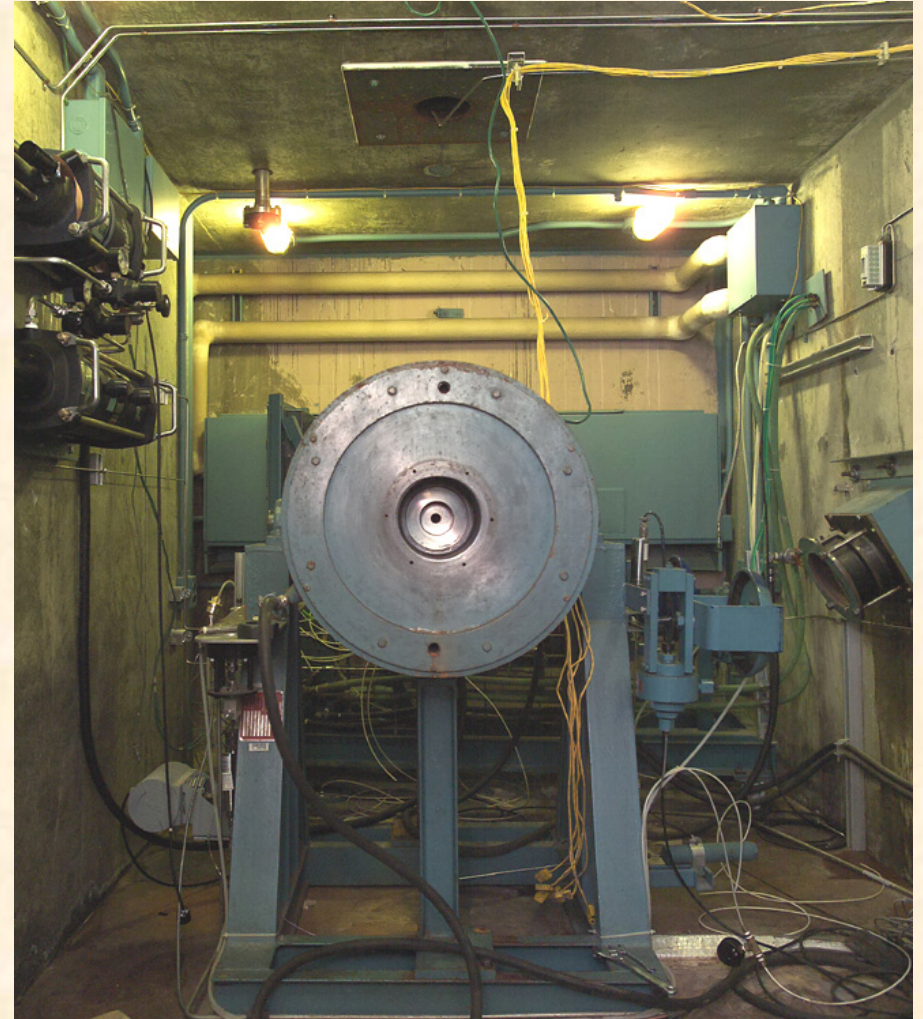

Capability of ORNL's IHPV high-pressure H₂ testing apparatus

- High hydrogen pressures can be achieved between room temperature to 1000C
 - Vessel rated for operation at pressures up to 120,000 psi
- Pressure measurements up to 3500 psi, accurate to 0.1 psi
- Temperature measurements accurate to 0.1°C.
- A large internal “working cavity”
- The entire facility is designed and engineered for safety

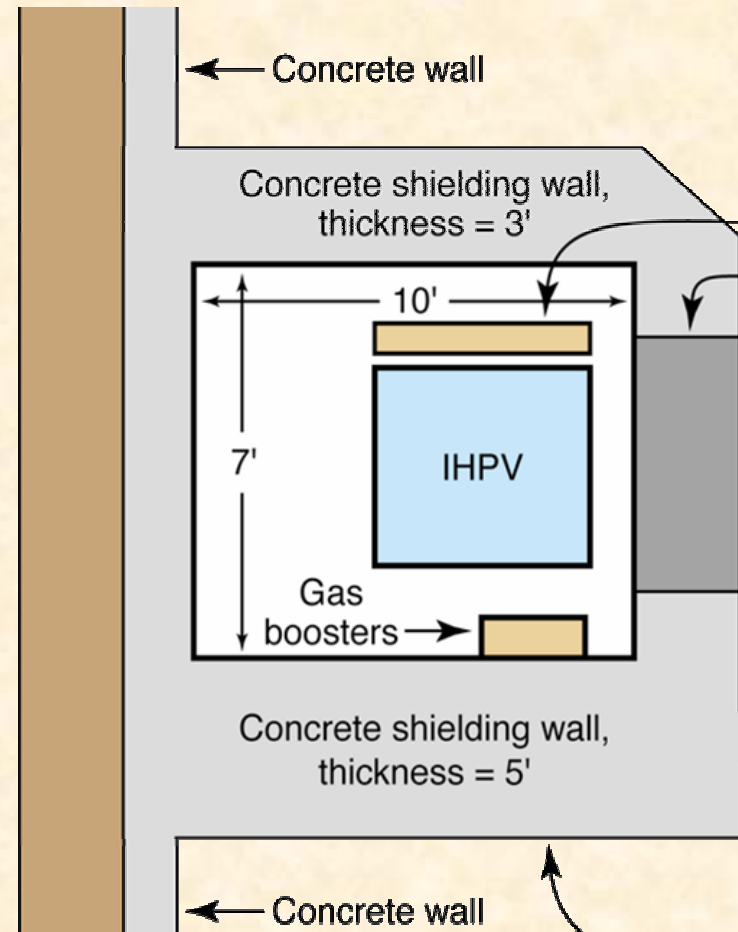

ORNL's IHPV high-pressure H₂ test apparatus

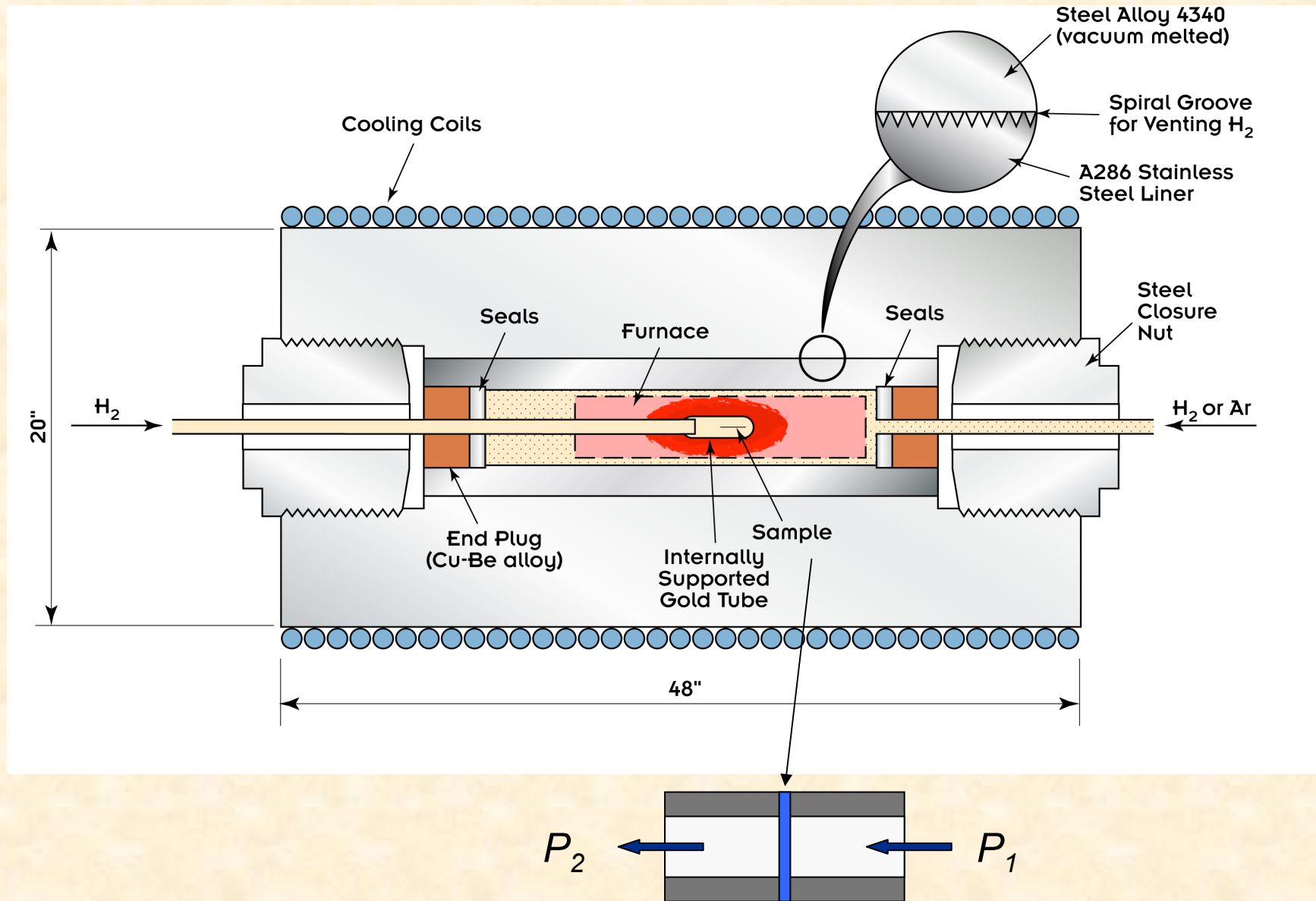

The high-pressure permeation sample holder was designed safety and efficient sample transfer

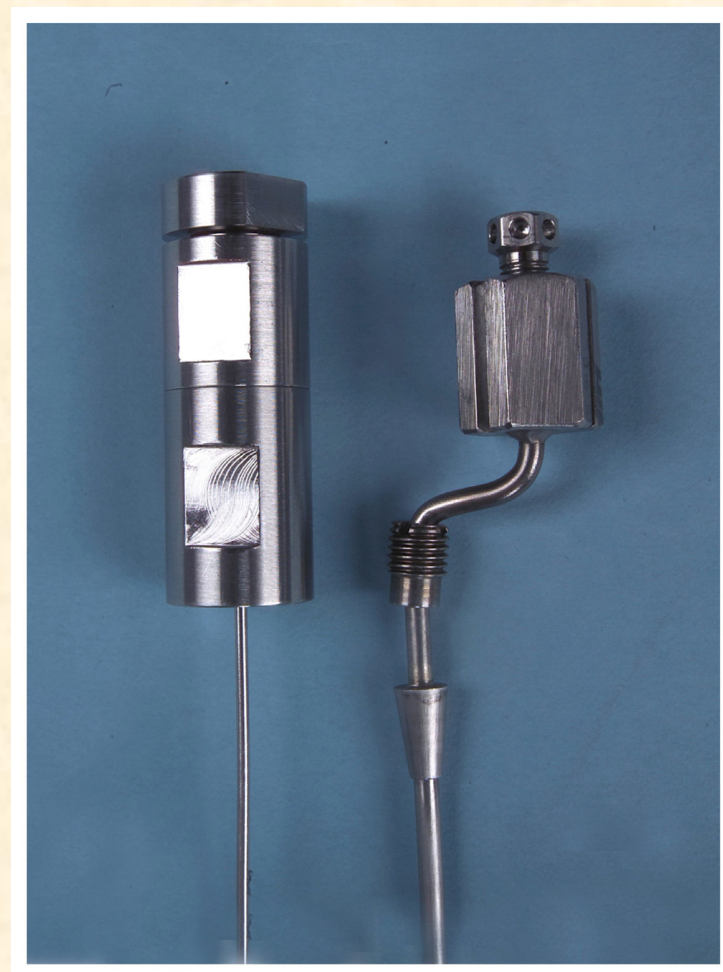
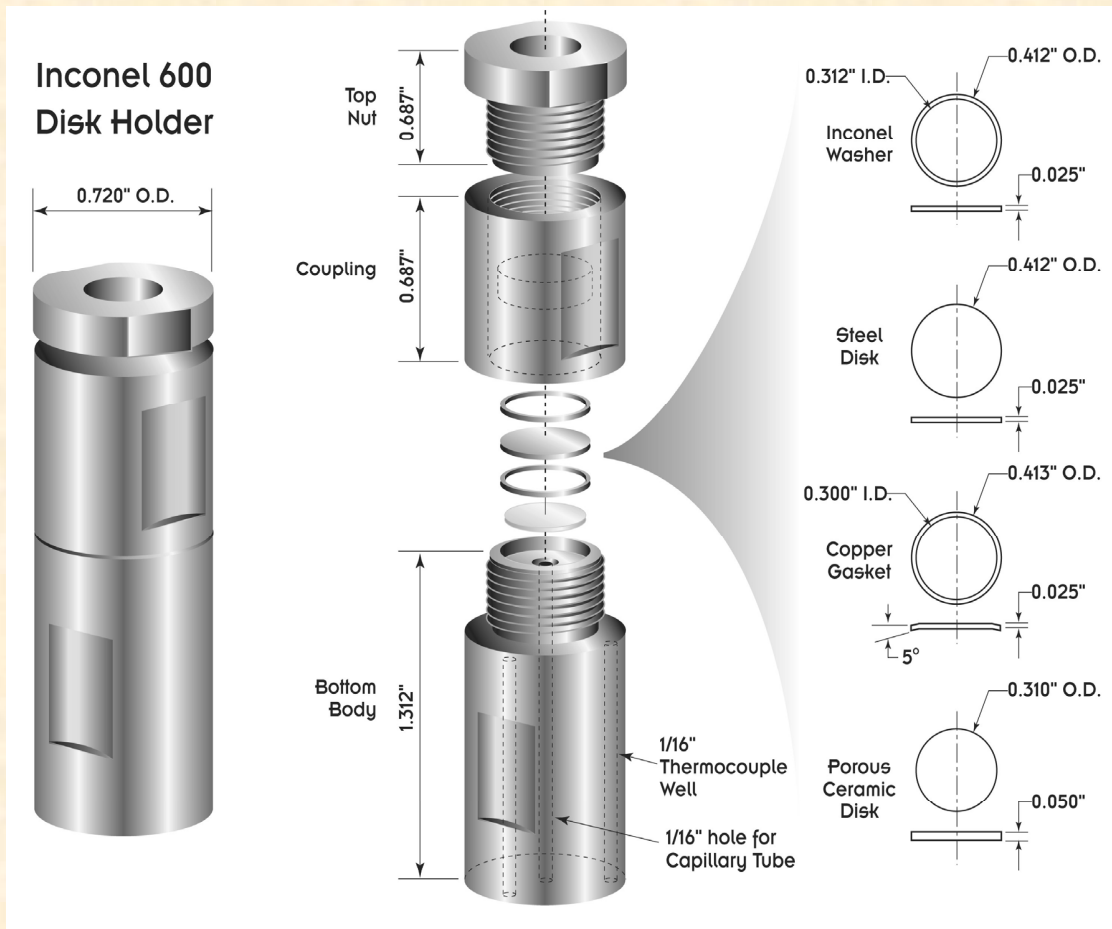

ORNL's high-pressure H₂ testing apparatus

- The apparatus is in the final validation testing stage
- High-P H₂ permeation testing procedure is being developed
- Expected to be available in May for permeation testing
- Design of mechanical testing apparatus is underway

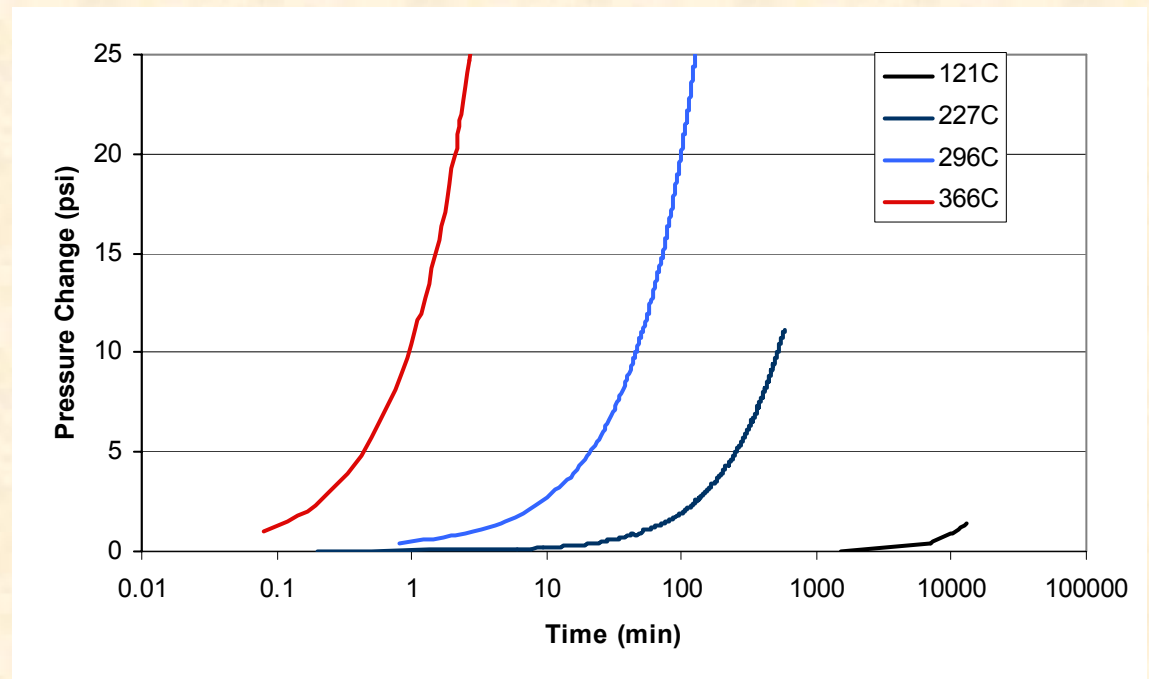

API X52 steel, tested at 450 psi and different temperatures

In parallel to high pressure test, we also developed a low-pressure permeation test

Simple conflat flange design made of the testing steel



SRNL's low pressure test set-up:
up to 1000 torr (19 psi) & 500°C

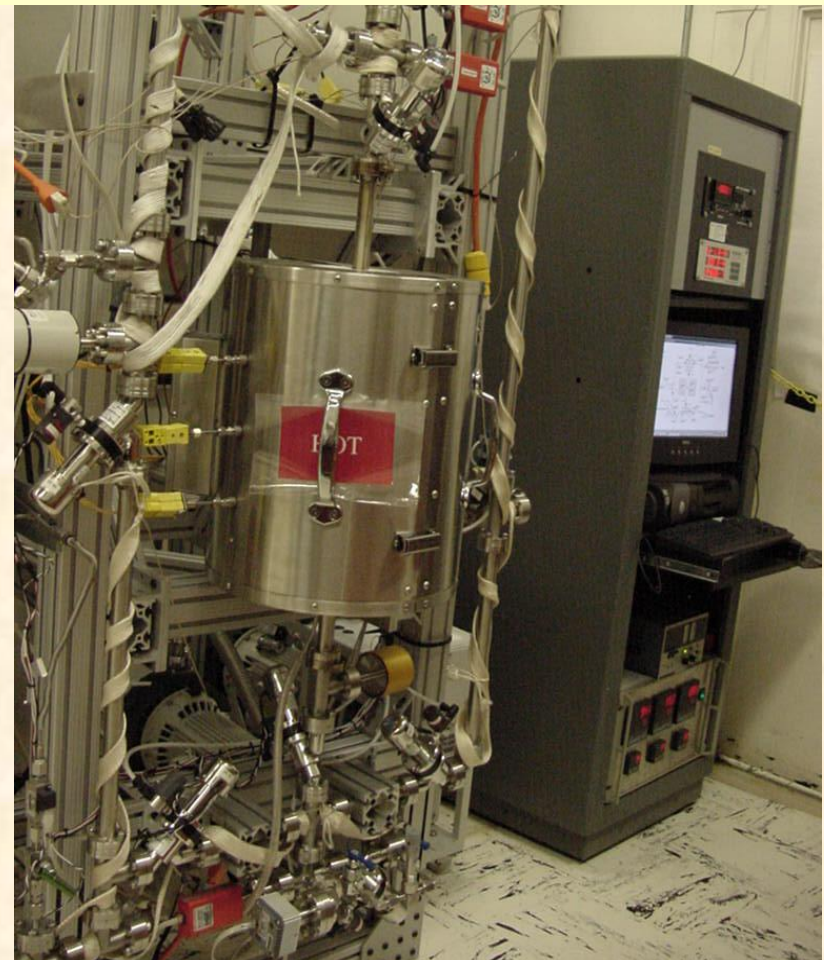

X65 steel shows lower permeability than X52 steel

- Testing conditions
 - 700 torr pressure differential at 100°C
 - API X-52 and X-65 pipeline steels
- Diffusivity of H
 - X52: $2.681 \times 10^{-7} \text{ cm}^2/\text{s}$
 - X65: $2.570 \times 10^{-7} \text{ cm}^2/\text{s}$

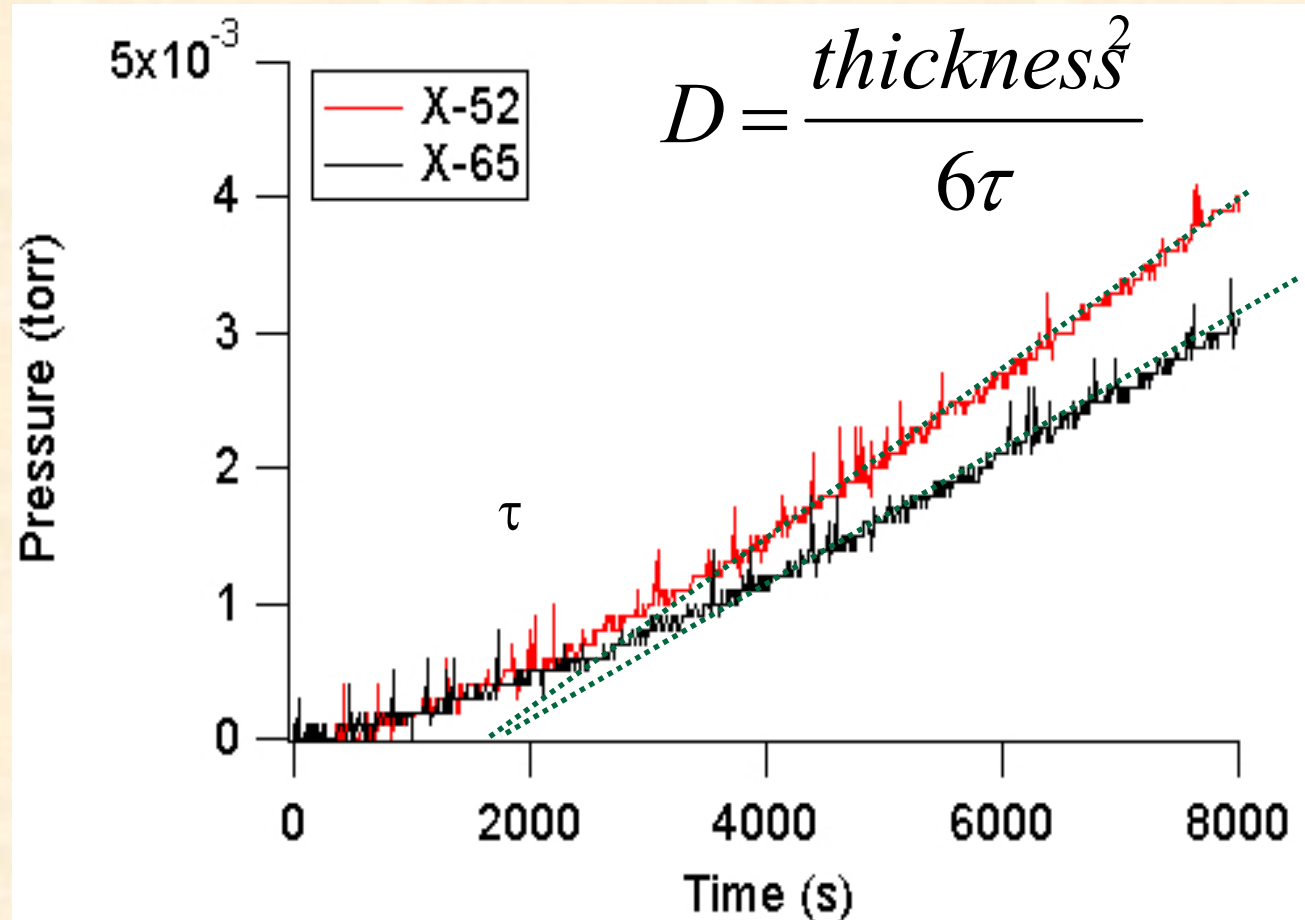

- This is consistent both in unsaturated and saturated tests.

The measured diffusivity is close to the published data and within the scatter reported

- Measured diffusivity through electrochemical technique (Dean 2002) in Fe-C-Mn steels at 200°C is 3.2×10^{-5} cm²/s and at RT is 5.2×10^{-6} cm²/s.
- Current measured diffusivity is one order of magnitude lower than that measured using electrochemical technique.

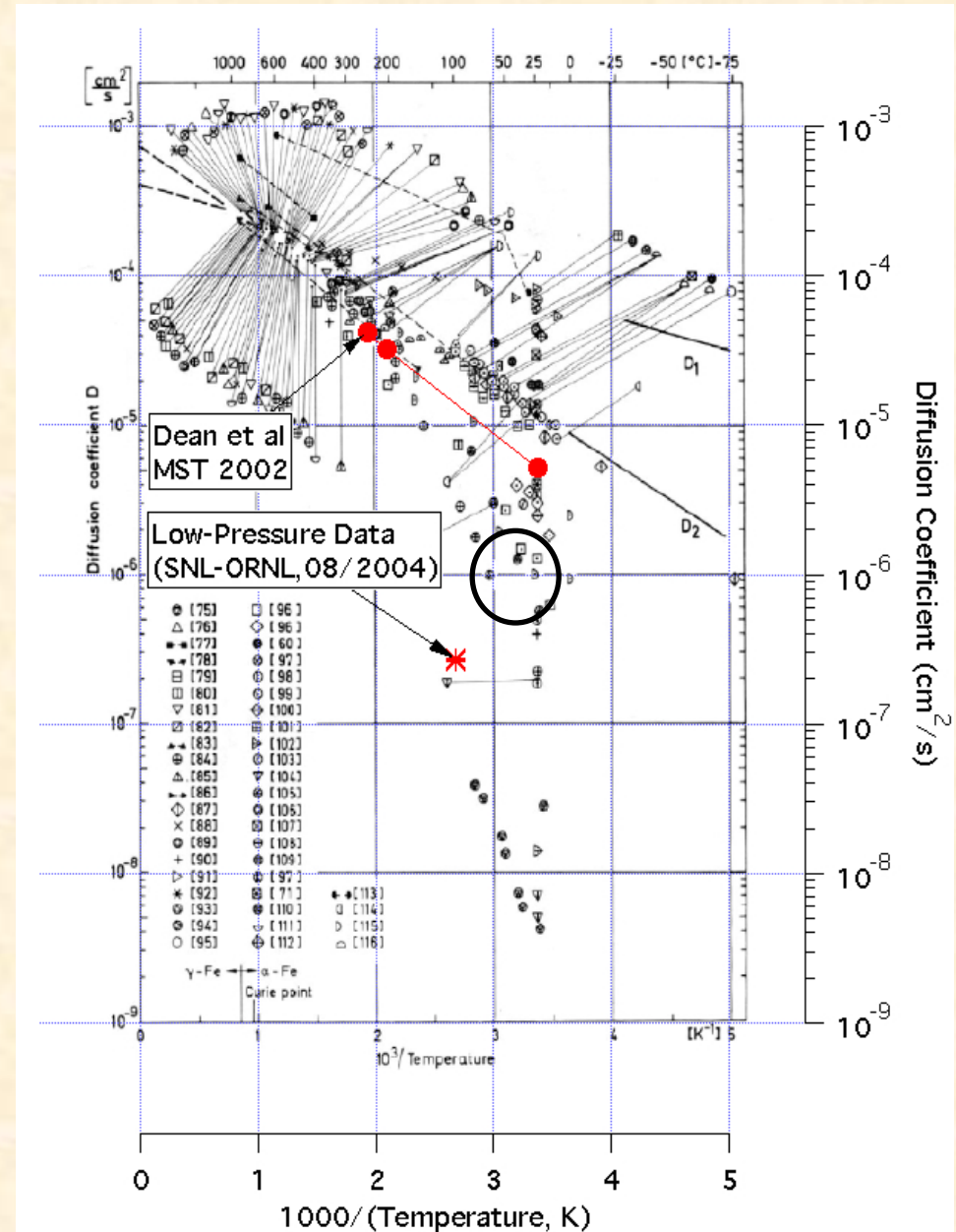

Responses to Previous Year Reviewers' Comments

- In last year's review, it was suggested to start with existing pipeline steels
- Accordingly, we obtained two steel pipe sections salvaged by pipeline companies from natural gas transmission pipelines
 - X52: 1952 production
 - X65: 1990 production

Future Work

- Remainder of FY05
 - Permeability studies (both low - pressure and high-pressure) on X52, X65 and WM
 - Production of well controlled microstructures
 - Surface conditions effects
 - Microstructural characterization on X52, X65 and WM
 - Characterization of microstructure before and after hydrogen charging
 - Mechanical property on X52 and X-65 and WM
 - Mechanical property measurements before and after hydrogen charging
- FY06
 - In-situ testing under high-pressure hydrogen
 - Evaluation of modern hydrogen embrittlement resistance high-strength steels under high-pressure H₂ environment
 - Effects of welding
 - Microstructural control in weld metal
 - Computational weld mechanics
 - Welding residual stress management

Supplemental Slides

The following three slides are for the purposes of the reviewers only – they are not to be presented as part of your oral or poster presentation. They will be included in the hardcopies of your presentation that might be made for review purposes.

Publications and Presentations

None

Hydrogen Safety

The most significant hydrogen hazard associated with this project is:

- Small volume, high-pressure H₂ in confined space in IHPV high-pressure apparatus

Hydrogen Safety

- Our approach to deal with this hazard is:
 - The entire IHPV is designed and constructed for high-pressure H₂ experiment
 - It is enclosed in heavy concrete shielding walls
 - Remote operation
 - ORNL has gone through an extensive safety review process of the proposed high-pressure H₂ tests in this program and other related hydrogen programs
 - A laboratory safety summary has been developed specifically for these tests to ensure the safety of testing personnel and equipment