

New York State Hi-Way Initiative

General Electric Global Research Center
22 May 2005

Richard Bourgeois, P.E.



imagination at work

Project ID #PDP10

This presentation does not contain any proprietary or confidential information

Overview

Timeline

Project start date 1 April 2004

Project end date 30 Dec. 2005

Percent complete 90%

Budget

Total project funding	M\$2.1
• DOE share	M\$1.4
• Contractor share	M\$0.7
Funding received in FY04	M\$1.05
Funding for FY05	M\$0.35

Barriers addressed

Q. Capital Cost of Electrolysis Systems

T. Renewable Integration

Technical Targets:

2005: Electrolyzed Hydrogen @ \$2.50 / kg

2010: Electrolyzed Hydrogen @ \$2.00 / kg

Partners

SUNY Albany
Nanotech

Objectives

- Develop a commercial strategy for low cost alkaline electrolysis
- Demonstrate a laboratory scale proof of concept electrolyzer
- Address market barriers to hydrogen infrastructure development in New York State

Approach

Quantify Market Requirements

- Establish customer and mission profile
- Determine target product size and configuration

Design System

- Set performance targets to meet customer requirements
- Identify technical barriers in development path

Electrochemical Cell Analysis

- Develop and test materials for low cost electrolyzer stack
- Optimize system cost, performance, and reliability

Bench Scale Testing

- Build and test proof of concept system

Full Scale Installation Concept

- Design reference plant

Marketing Study

- Identify opportunities for H2 business acceleration in NY State
- Identify barriers to hydrogen infrastructure implementation

Customer Pull Driving GE Technology Solution



- \$2 / kg
- clean H2
- scalable

Utilities

- off-peak asset utilization
- grid support
- distribution growth

Oil & Gas Companies

- fueling vision
- global reach
- systems expertise

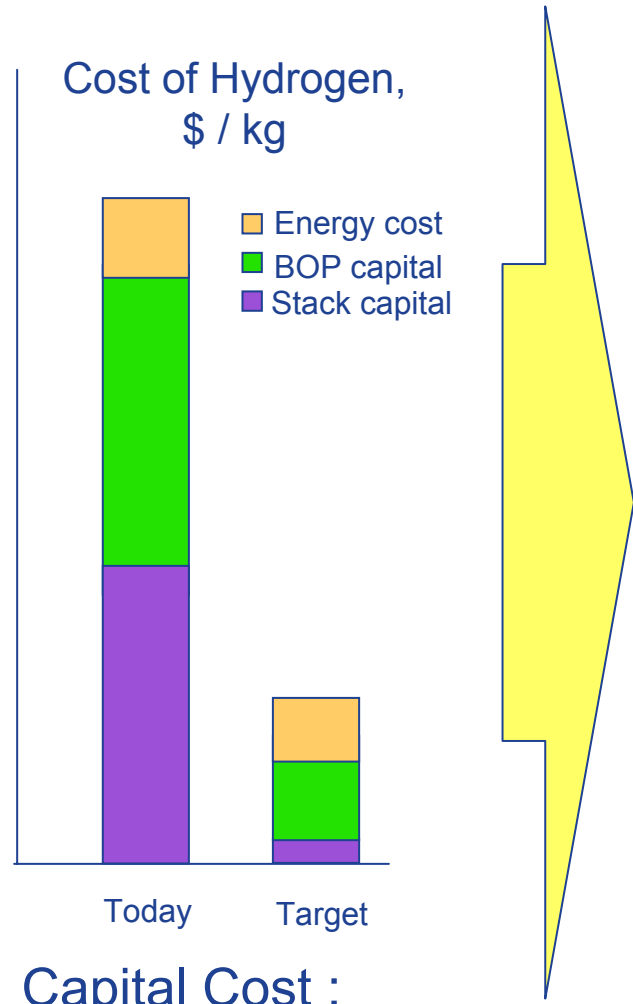

Capital Cost :
Key to Market Entry

Stack Cost-Out Through Technology

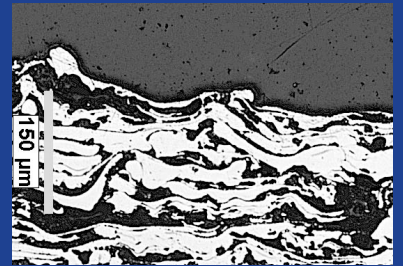

high surface electrode

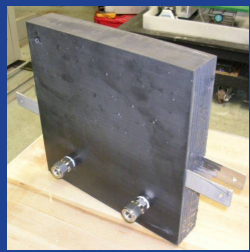

monolithic design

System Cost-Out Through GE Process

Optimizing H2 Cost Drives Tradeoffs

Voltage / Current Tradeoffs

Baseline IV curve

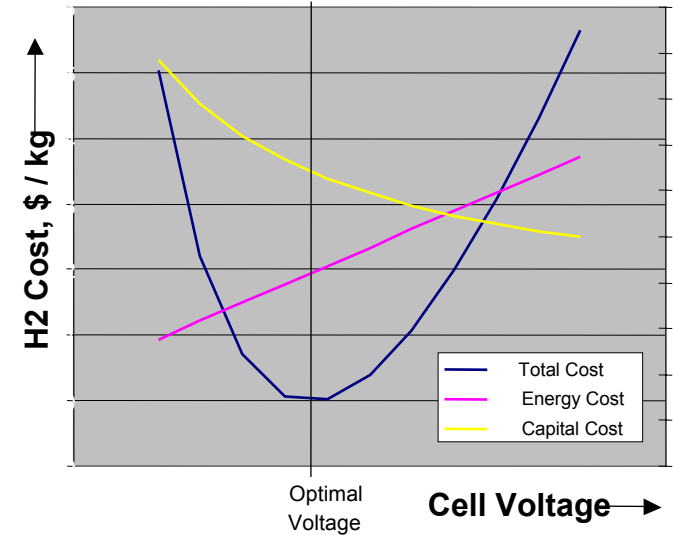
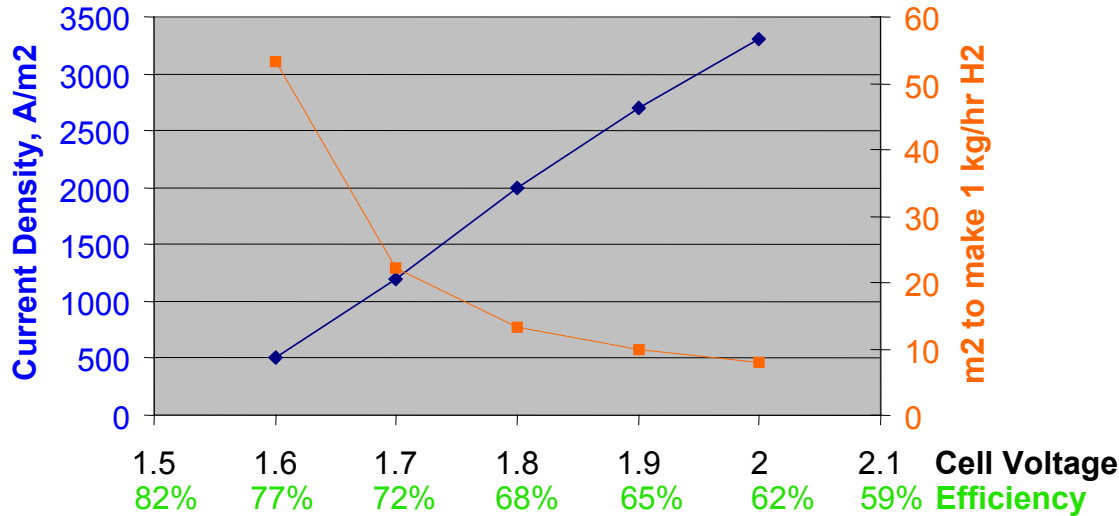

← minimizes energy costs → minimizes capital costs

Lowest cost operating point varies with cost of electricity and specific cost of material

Technology Plan for Stack Cost

High surface area electrodes minimize stack size

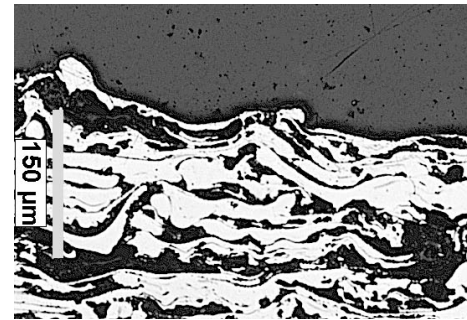

Advanced materials enable low assembly costs

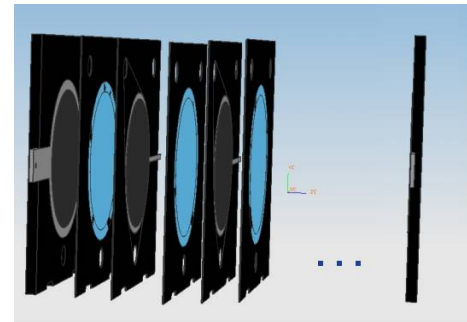

Alkaline Electrolyzer Design Basics

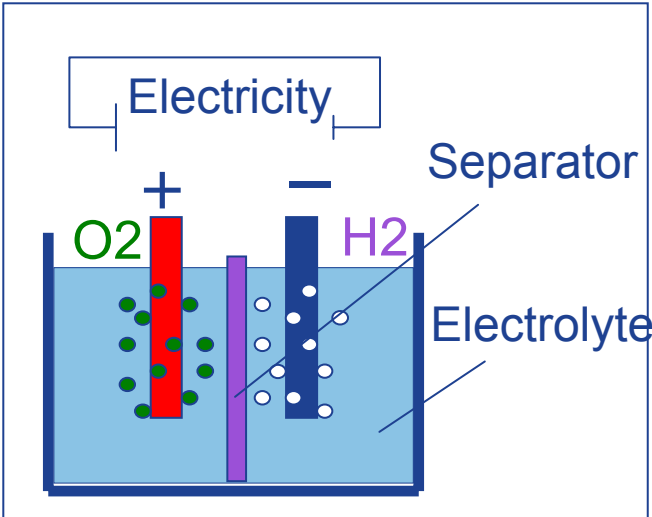

Single Unipolar Cell

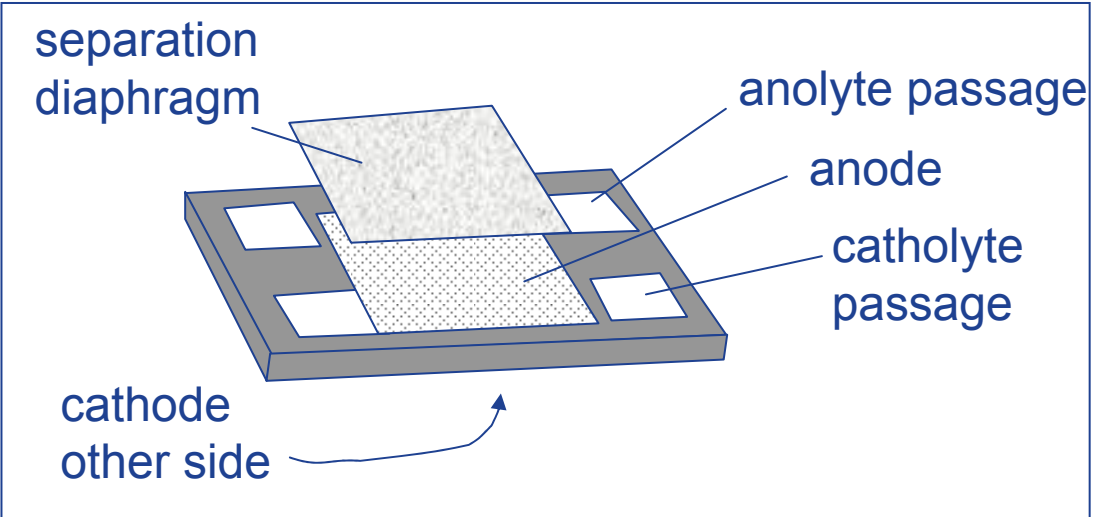

Bipolar type half-cells

Cathode (-):



Anode (+):

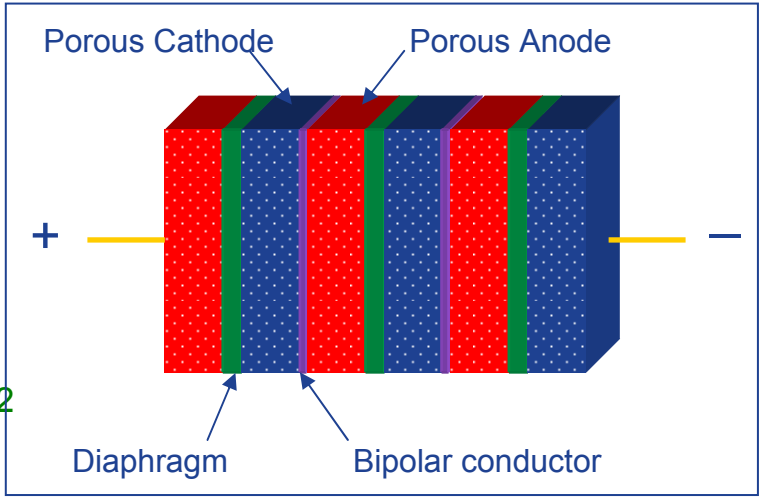

Multicell Bipolar Stack

Electrode Concept Selection

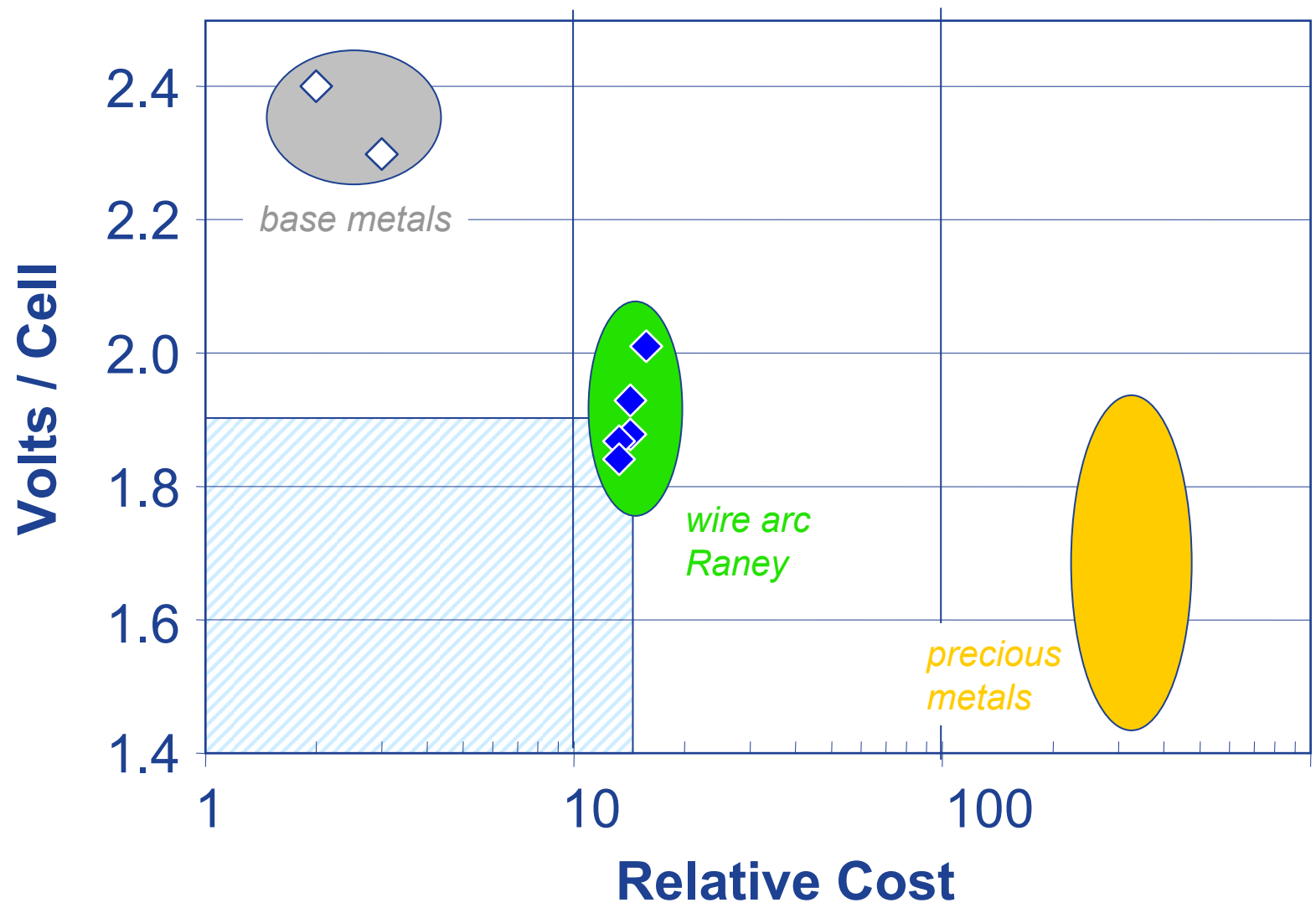

Wire arc Raney meets targets

Wire Arc Single Cell Data

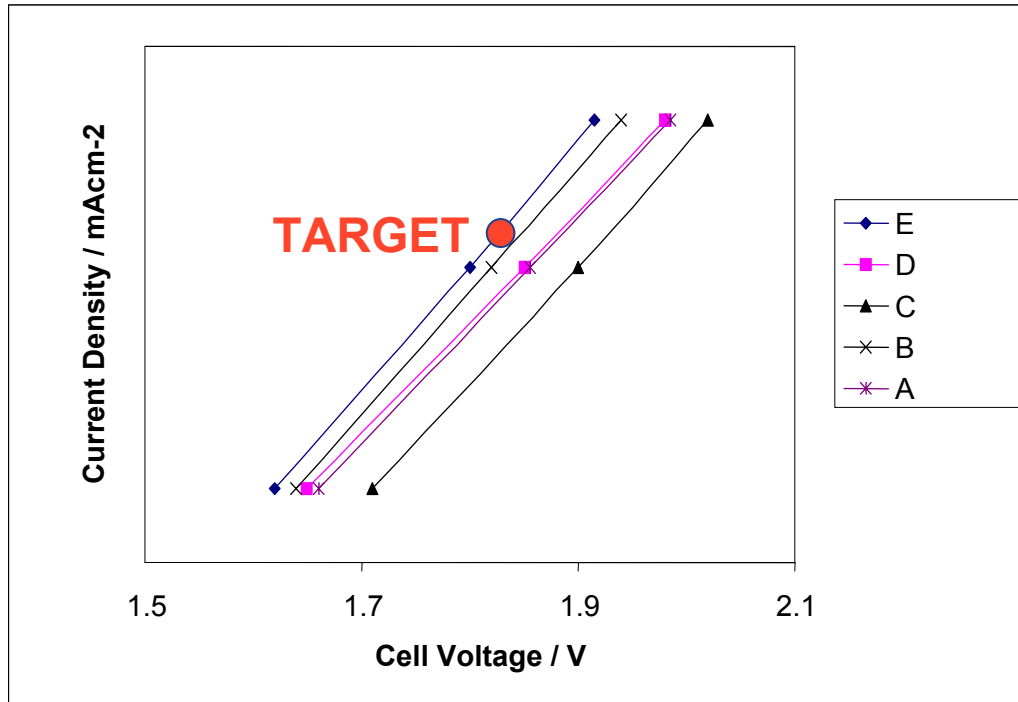

single cell test stand

All electrodes at or close to target
Electrode “E” the choice to go forward

Stack Design

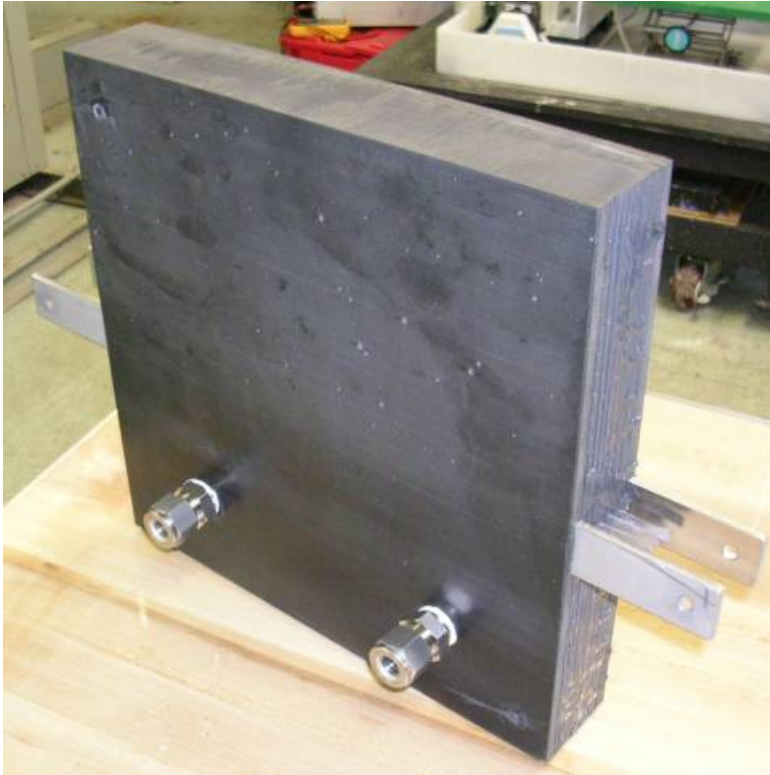

5 x 153 cm² cells

500W input power

10 grams H₂ / hour output

GE advanced plastic material

Plate / epoxy construction

Wire arc coated electrodes

Dual inlets to eliminate shunts

First “true monolith” – design details per product concept

500W Bench Scale System

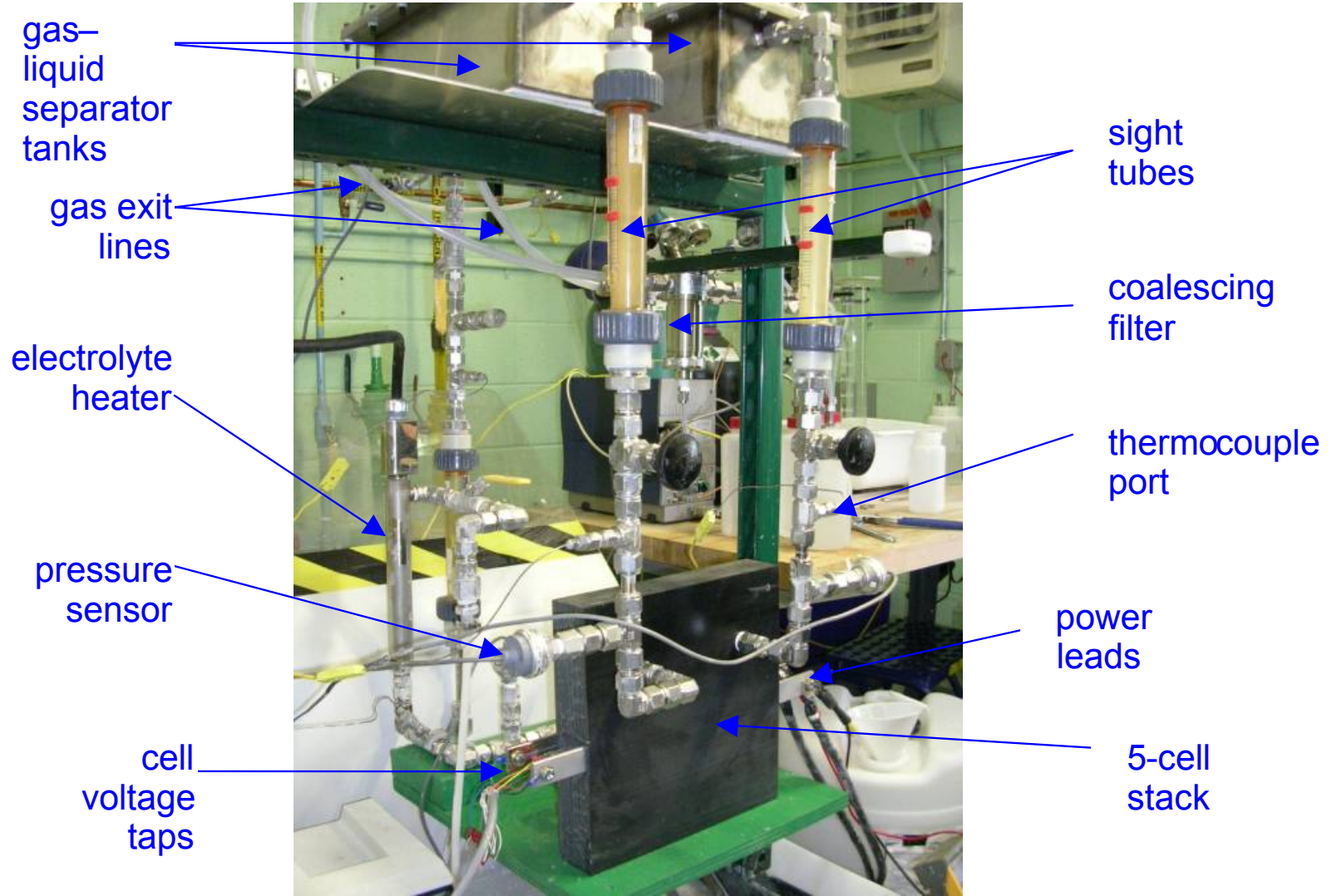
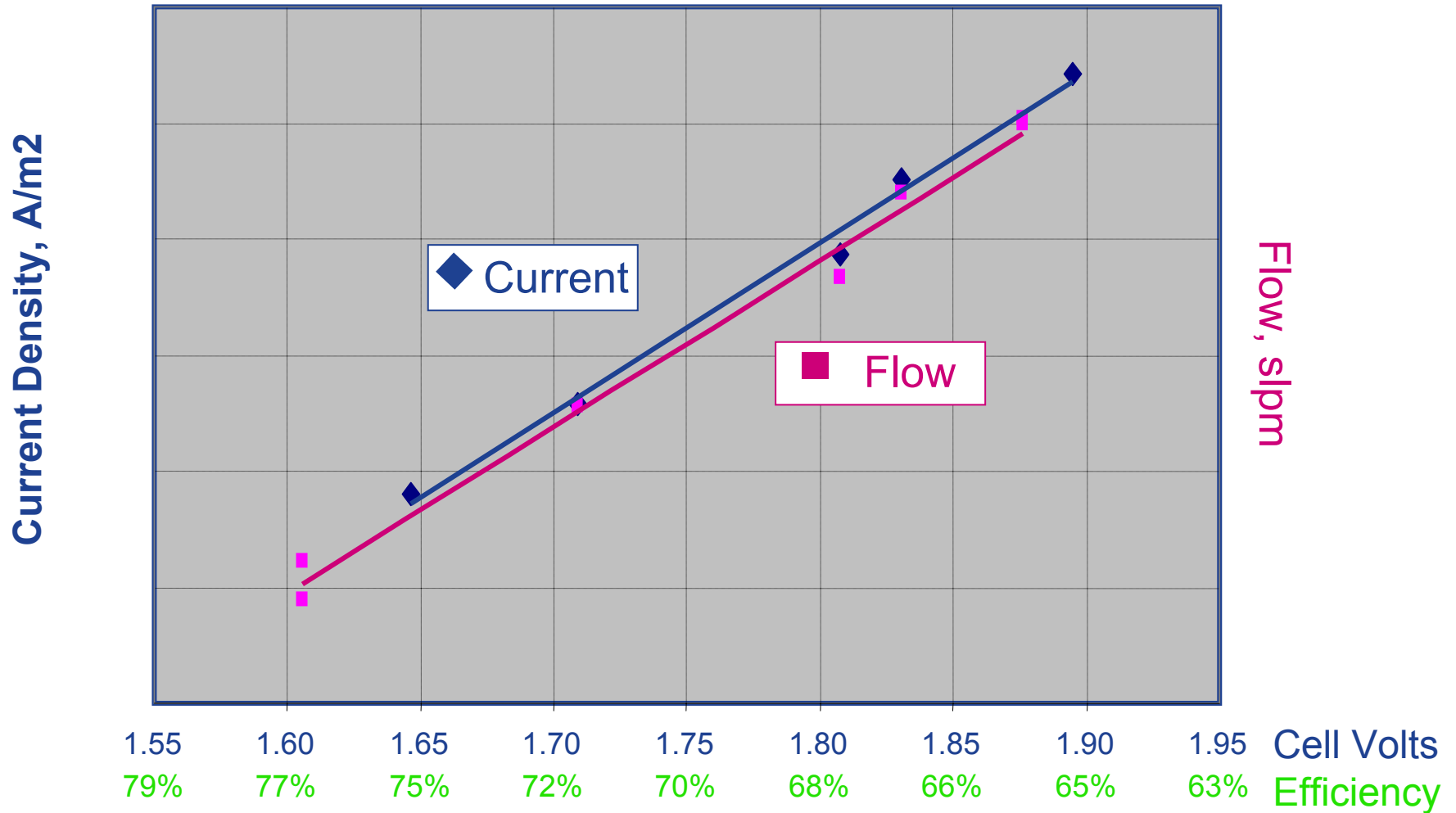

Figure 5: Bench Scale Test Stand

5-Cell Stack Test Data



Cell tests show entitlement to reach performance target
H2 production rate 99% of input current equivalent

Bubble Effect on Cell Performance

Voltage Waterfall

O2 bubbles mask anode, increasing overpotential

H2 bubbles mask cathode, increasing overpotential

Bubbles displace electrolyte, lowering effective conducting area.

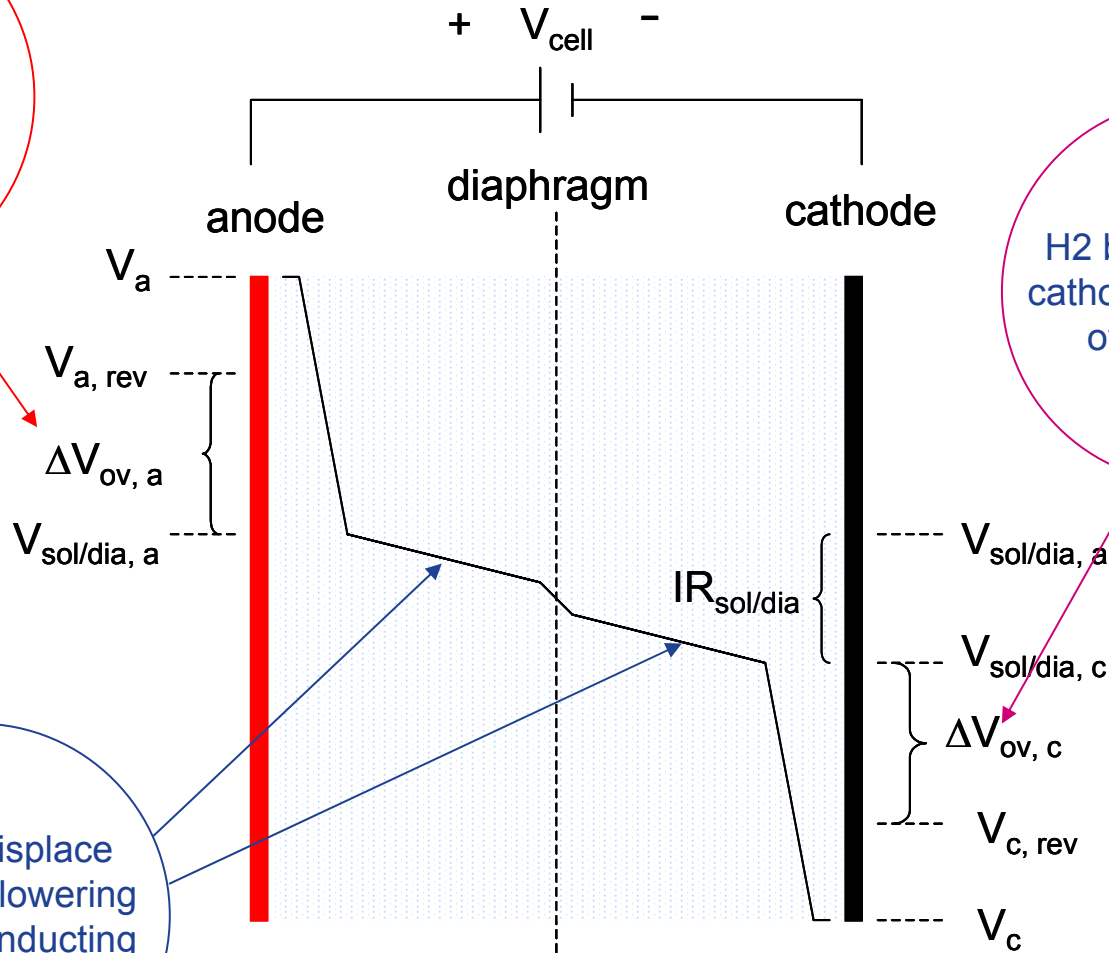

Challenge: Model Bubbles in a Working Cell

Highly non-linear problem requiring development of advanced models

- Multi-phase turbulent flow
- Porous media
- Electrochemical reactions
- Electron/Ion transport
- Dissolved species

Governing Eqs.

Mass
Momentum
Species
Energy

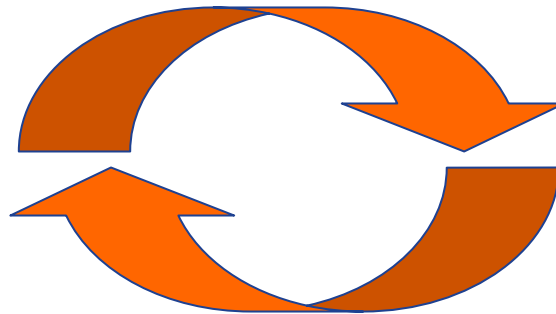

Additional Physics

Butler-Volmer Kinetics
Ionic Potential Field
Species Sink/Source
Energy Sink/Source

2D CFD Results

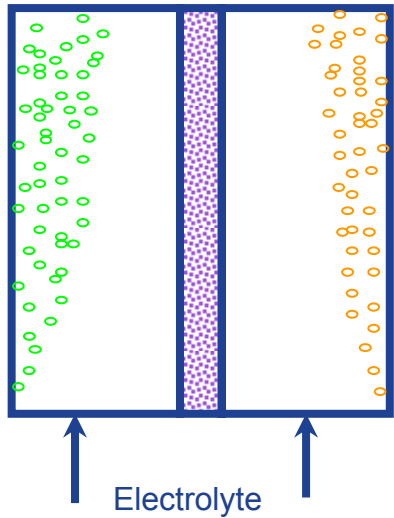

Simplified model / experimental geometry

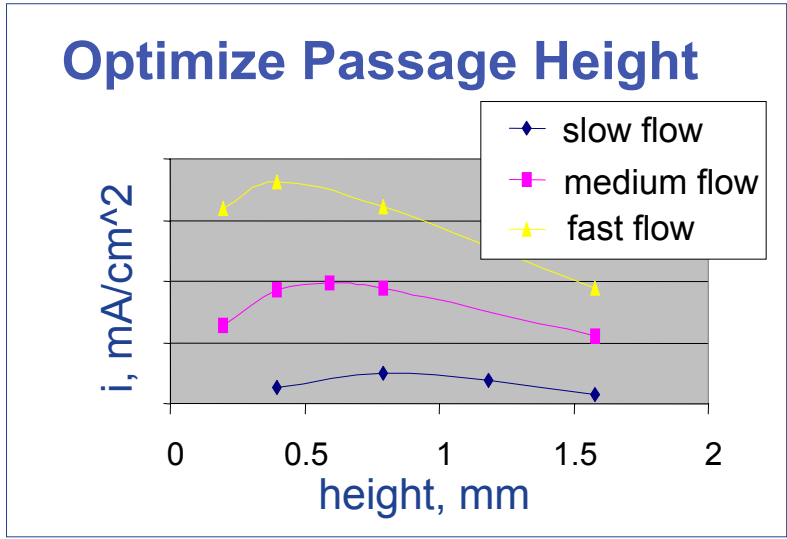
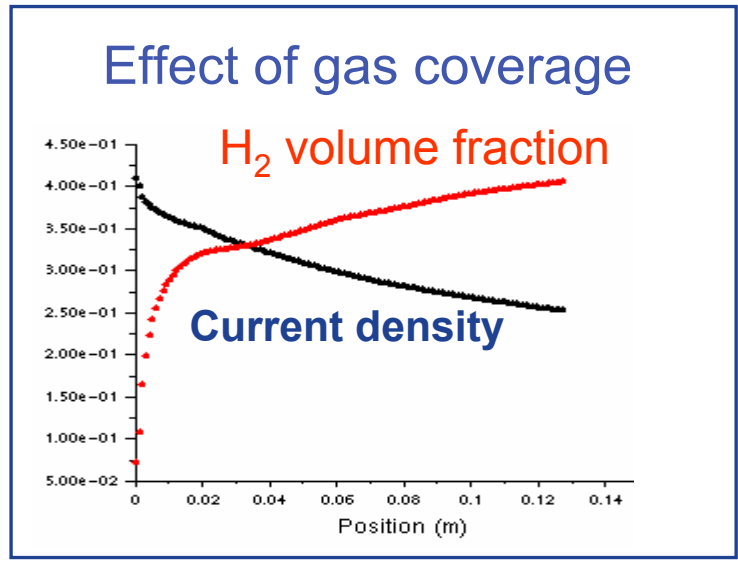
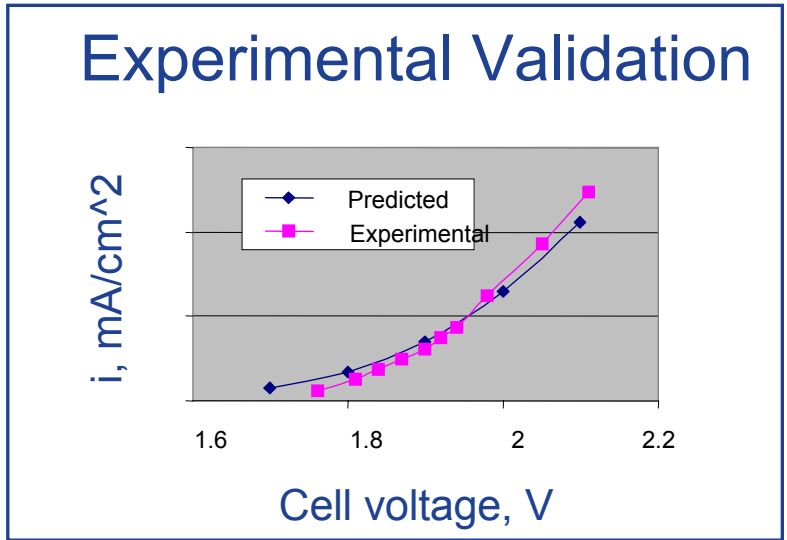

50 kW Stack Manufacturing

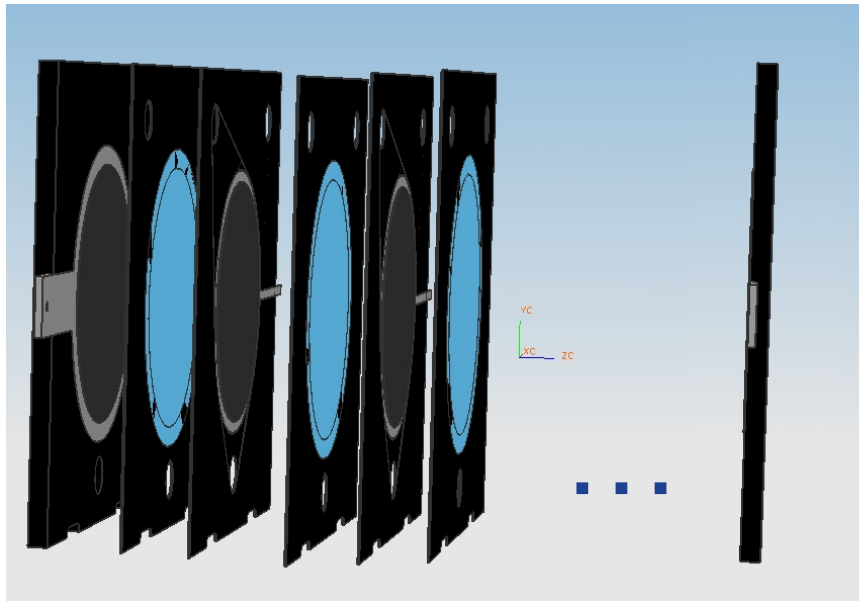

molded
automotive
product

2005 stack: “one-off” construction
Advanced joining methods by GEAM

Molding becomes method of choice at 100's of units / year

Diaphragm Characterization Testing



single cell test stand

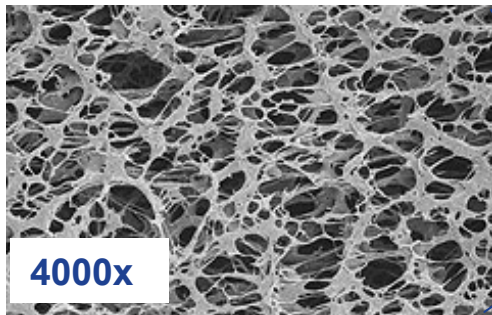

4000x

Diaphragm requirements:

resists gas bubble crossover
highly wettable
low specific electrical
resistance

Membrane Material	Pore Size (um)	Bubble Point (psi)	Water Flux (ml/min/cm ² @10psid)	ASR (ohm*cm ²)
Polypropylene	7 um - non weave	0.14	123	3.655
Polypropylene	0.22	15	3	397.8
Polyethersulfone	0.22	60	33.2	1.8 +/-0.1 (n=3)

Initial characterization of commodity diaphragm materials

H2 Energy System Optimization

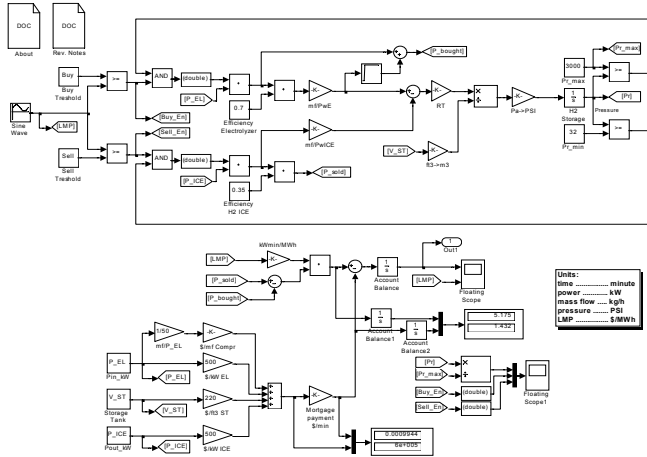
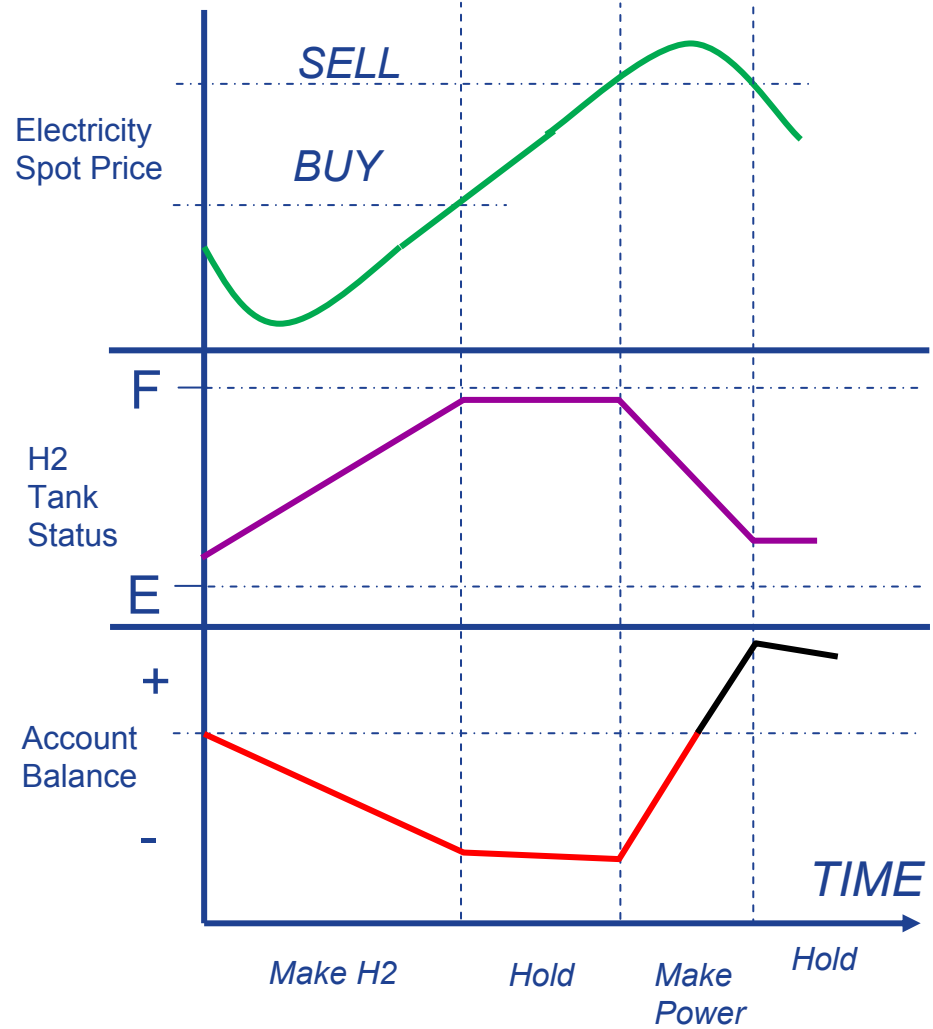
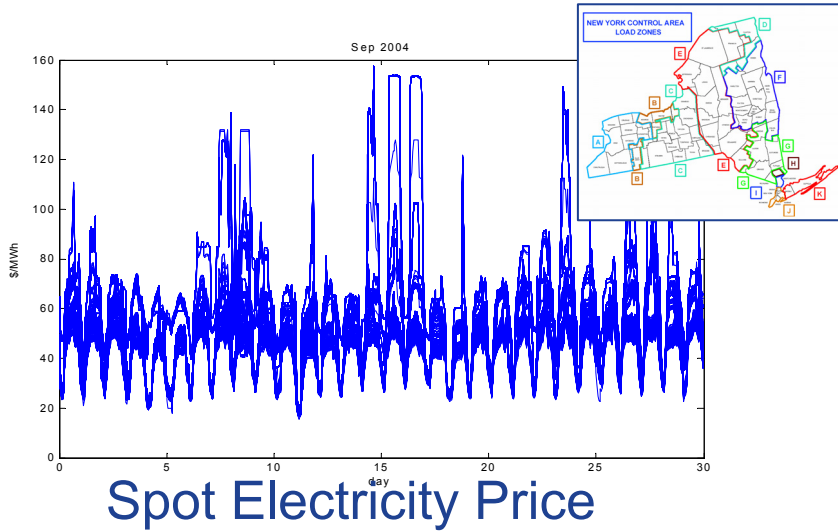

Electrolyzer / H2 ICE System Model

Reference Power Park Design

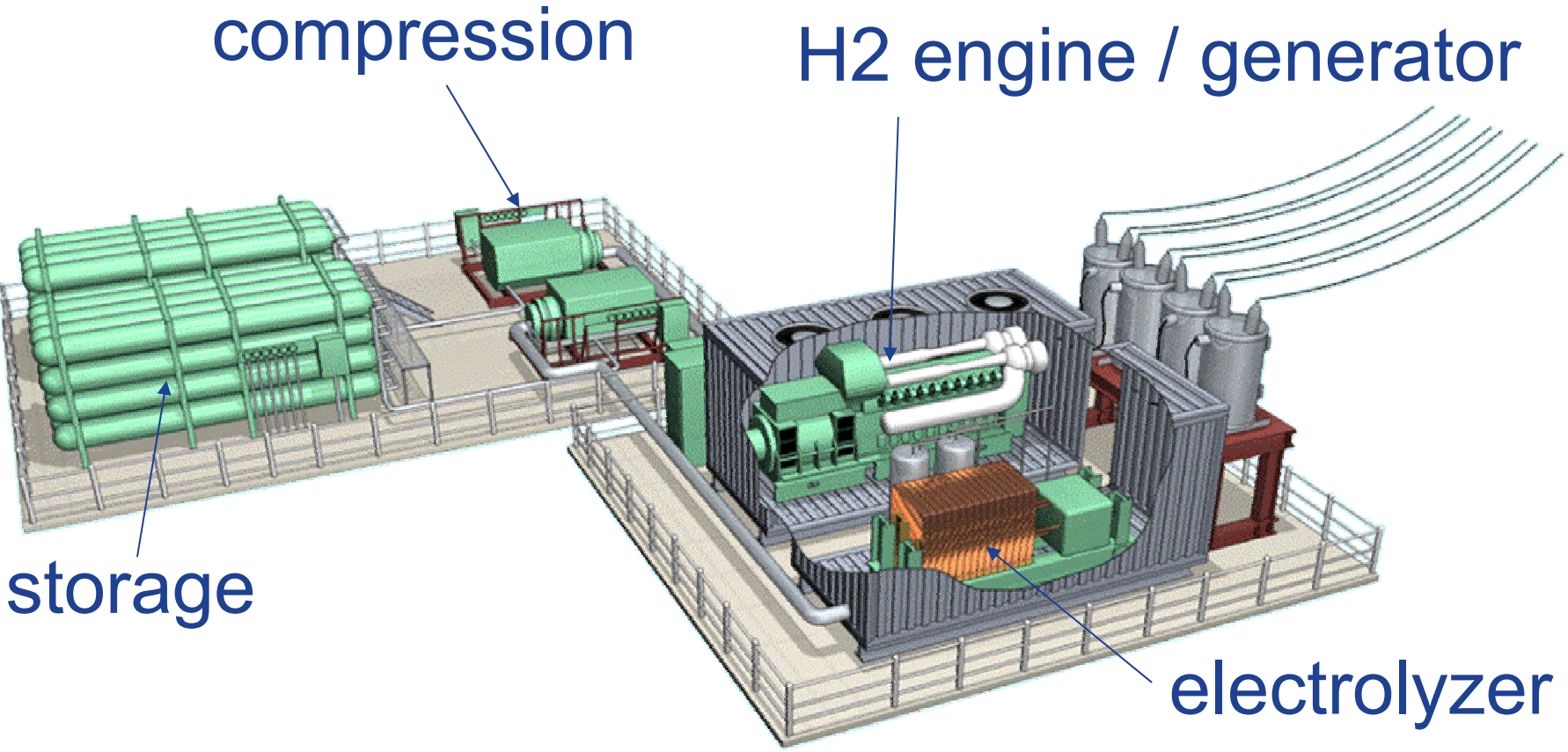

MW scale building block for utility or fueling application

Future Work

- Scale up cells for utility-sized stacks
- Study long term effects on electrode performance
- Build a prototype system incorporating full size cells

Stack Scaleup to 50 kW system

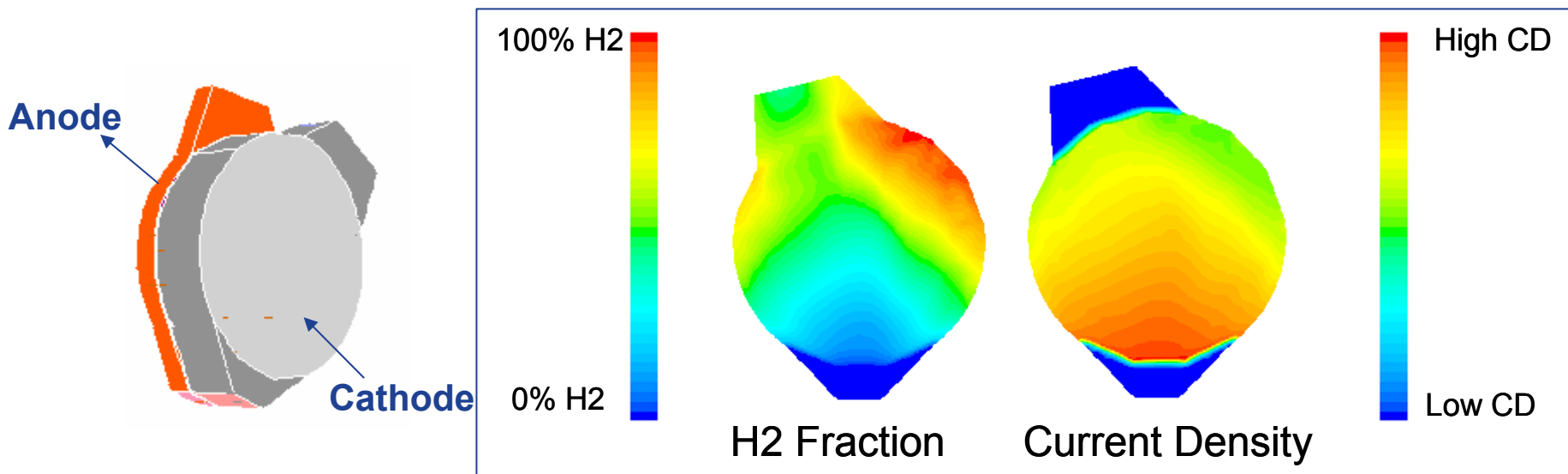

baseline round cell

3D electrochemical CFD capability enables fast geometry optimization

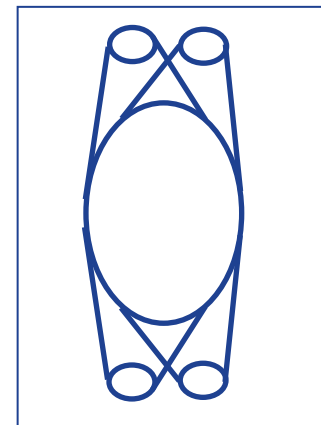
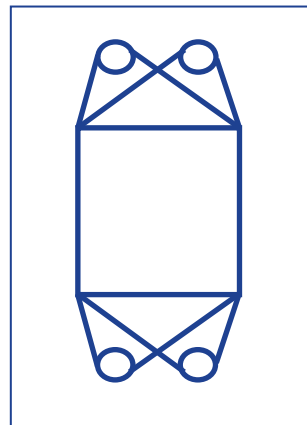

square cell elliptical

Long – Term Electrode Performance

Degradation: study and mitigate change in overvoltage over operating life

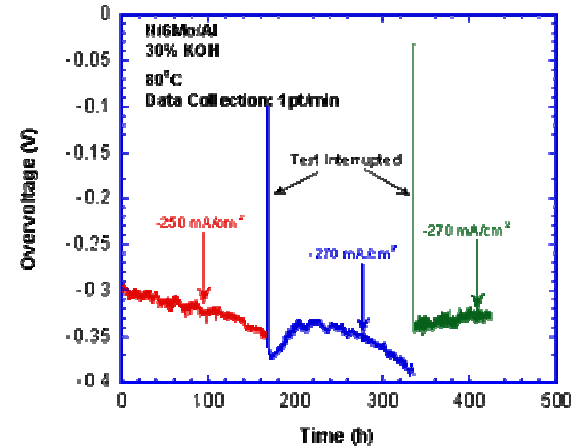

Reliability: electrode loss in high current operation

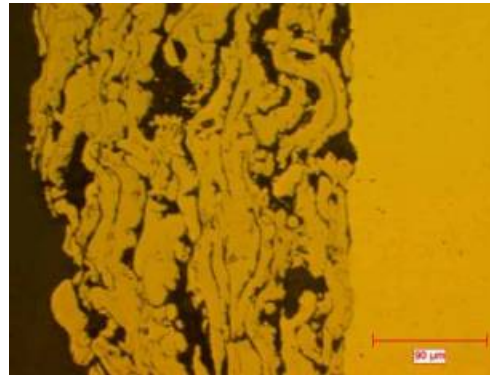

Electrode deposited on substrate, as received

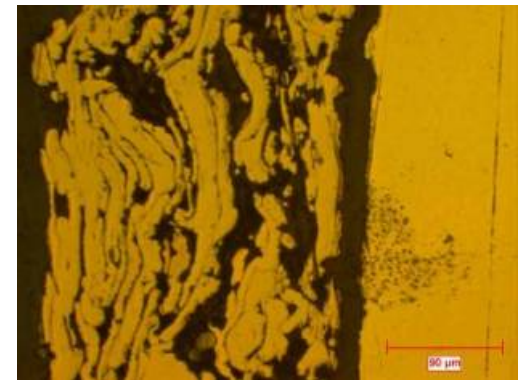

Delamination after highly accelerated stress test

50 kW System - 2005

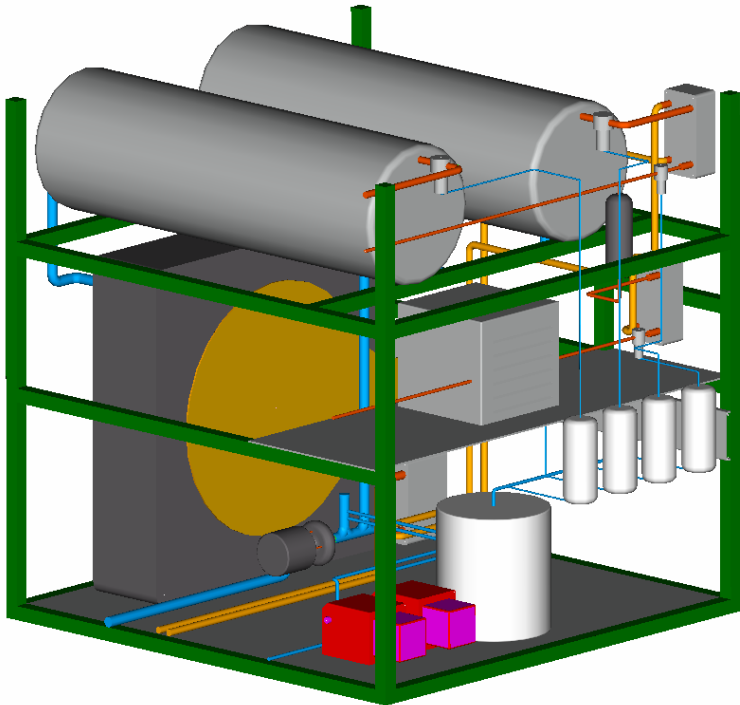

Capabilities:

- 1 kg H₂ / hr production rate
- High pressure operation
- Automated controls
- P, T, massflow, purity measurements

Opportunity for total instrumentation
Study operability & maintenance characteristics

Publications and Presentations

The following papers on hydrogen sensor technology have been accepted for publication:

Z. Zhao, M. A. Carpenter, H. Xia, D. Welch, "All-optical hydrogen sensor based on a high alloy content palladium thin film", Sens. Actuators B., accepted for publication March 2005.

Z. Zhao, M. A. Carpenter, "Annealing enhanced hydrogen absorption in nanocrystalline Pd/Au sensing films", J. Appl. Phys., accepted for publication April 2005.

On 12 April 2005, a the invention of a plastic monolithic electrolyzer stack was filed with the U.S. Patents and Trademarks office.

Hydrogen Safety

The most significant hydrogen hazard associated with this project is the possibility of an abnormal condition resulting in a leak in the hydrogen production system.

If an ignition source is also present such a leak could result in a fire.

Hydrogen Safety

At the GE Global Research Center, the Environmental Health and Safety (EHS) team reviews all experiments. All hydrogen producing systems in this project are contained within laboratory spaces incorporating the following safety features:

- Ventilated hoods
- Flammable gas detectors
- Automatic shutoff on sensing gas or ventilation failure
- Manual emergency stops inside and outside building
- Posted SOP detailing normal and emergency operation
- Required training for all operators

In addition, novel hydrogen sensors are being developed by subcontractor SUNY Nanotech.