



Low Cost Hydrogen Production Platform

Cooperative Agreement: DE-FC36-01GO11004
Project ID #: PDP4

Timothy M. Aaron

Team

Praxair - Tonawanda, NY

Boothroyd-Dewhurst - Wakefield, RI

Diversified Manufacturing - Lockport, NY

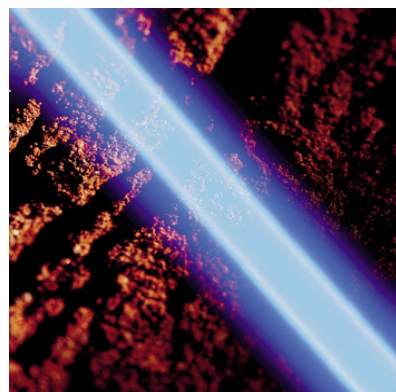
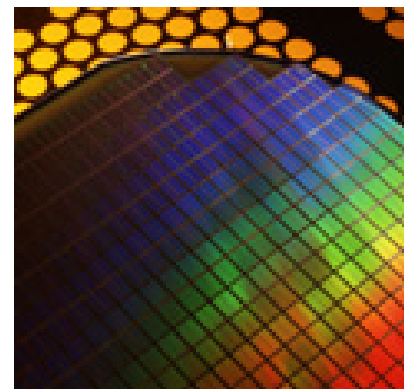

DOE Hydrogen Annual Review Meeting
May 23 - 26, 2005

Copyright © 2005 Praxair, Inc.

This paper was written with support of the U.S. Department of Energy under Contract No. DE-FC36-01GO11004. The Government reserves for itself and others acting on its behalf a royalty-free, nonexclusive, irrevocable, worldwide license for Governmental purposes to publish, distribute, translate, duplicate, exhibit and perform this copyrighted paper. This presentation does not contain any proprietary or confidential information.



LCHPP Program

- **Low Cost On-Site Production of Hydrogen**
 - Existing Technologies (SMR)
 - Transportation and Industrial (1,000 - 5,000 scfh) (2.4 - 12 kg/h)
- **Year in Review**
 - Proof of Phase I Design Concept
 - Detail Design and Engineering of System
 - Computer Simulations and Modeling
 - System Optimization
 - Component Testing
 - ◆ Design of Experiments
 - ◆ Procurement of Test Rigs
 - ◆ Testing of Components
 - Maintain/Reduce Overall Costs
 - DOE Requested Delay In Overall Program Schedule
 - Reduced FY2005 \$ / Move to FY2006 \$

Design Specifications

➤ Inputs

- Natural Gas or equivalent
 - 5-30 PSIG
 - Std Specifications
 - 850 SCFH
- Water
 - Std Potable Specs
 - <0.5 GPM
- Electrical
 - 220/480 VAC
 - 12 KW

➤ Outputs

- Hydrogen Product
 - 4.8 kg/h (2,000 scfh)
 - <10 PPM CO
 - >99% Purity
 - 100-120 PSIG
- Turndown Capabilities
 - 50% Minimum
- System Package
 - 7'-6" x 10' x 10'
 - 18,000 lbs

Project Timeline

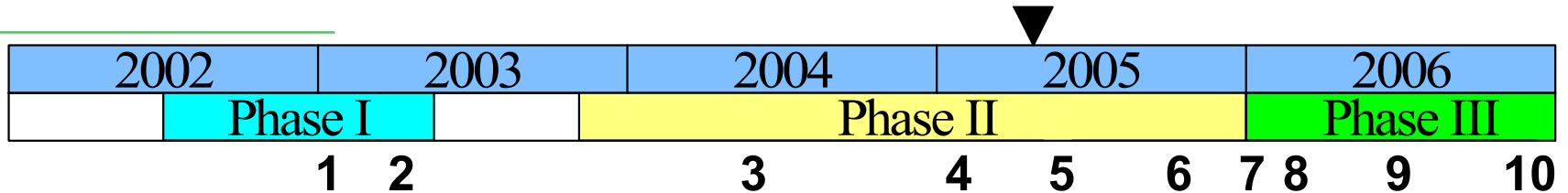

- **Phase I - Preliminary Design**
 1. Preliminary Component and System Design
 2. Techno-Economic Study
- **Phase II - Detail Design and Optimization**
 3. Detail Design and Computer Models
 4. Construct Test Apparatus
 5. Component Testing
 6. Update System Design and Economic Models
- **Phase III - Prototype System**
 7. Complete Prototype Design
 8. Build Prototype System
 9. Verify System Performance and Update Economics
 10. Commercialize System

Budget - LCHPP Program

- **Phase I**
 - Completed 06/03
- **Phase II (10/03 - 12/05) - In Progress**
 - Total Estimated Cost: \$1,989,933
 - Cost Share: 50/50 - DOE/Praxair
 - FY2004 DOE Funds (10/03 – 09/04) - \$120,000
 - FY2005 DOE Funds (10/04 – 09/05) - \$440,000 (Estimated)
 - FY2006 DOE Funds (10/05 – 09/06) - \$435,000 (Estimated)
- **Phase III (01/06 - 12/06)**
 - TBD

Barriers and Partners

- **DOE Barriers Addressed**
 - A. Fuel Processor Capital Costs
 - B. Fuel Processor Manufacturing
 - C. Operation and Maintenance (O&M)
 - D. Feedstock and Water Issues
 - F. Control and Safety

- **Program Partners**
 - Praxair Inc.
 - Industrial Gas Technology Leader
 - Boothroyd-Dewhurst Inc.
 - Design For Manufacturing and Assembly Experts
 - Diversified Manufacturing Inc.
 - High Temperature Component Fabrication Experts

Project Objectives

- **Low Cost On-Site Production of Hydrogen**
 - Gas Station Sized Unit (4.8 kg/hour)
 - Existing Technology
 - Steam Methane Reforming (SMR)
 - Pressure Swing Adsorption Purification (PSA)
 - System Optimization
 - Design For Manufacturing and Assembly (DFMA)
 - Develop Prototype System
 - Approach DOE Program Goals
 - Address DOE Technical Barriers
 - Commercialize System
 - Implement Into a Fueling Station
 - New Baseline for Low Cost On-Site H₂ Production

Approach

- **Develop Small SMR Based Hydrogen System**
 - Phase I (Completed)
 - Preliminary Design and Techno-Economic Study
 - Phase II (10/03 - 12/05)
 - Detail Design and Optimization
 - ◆ Increase System Efficiency
 - ◆ Lower Capital Cost
 - ◆ Comply/Develop Safety and Design Standards
 - Component Modeling and Testing
 - Catalyst Analysis
 - Economic Model Updates
 - Phase III (01/06 - 12/06)
 - Prototype System

LCHPP - Skid Process Flow

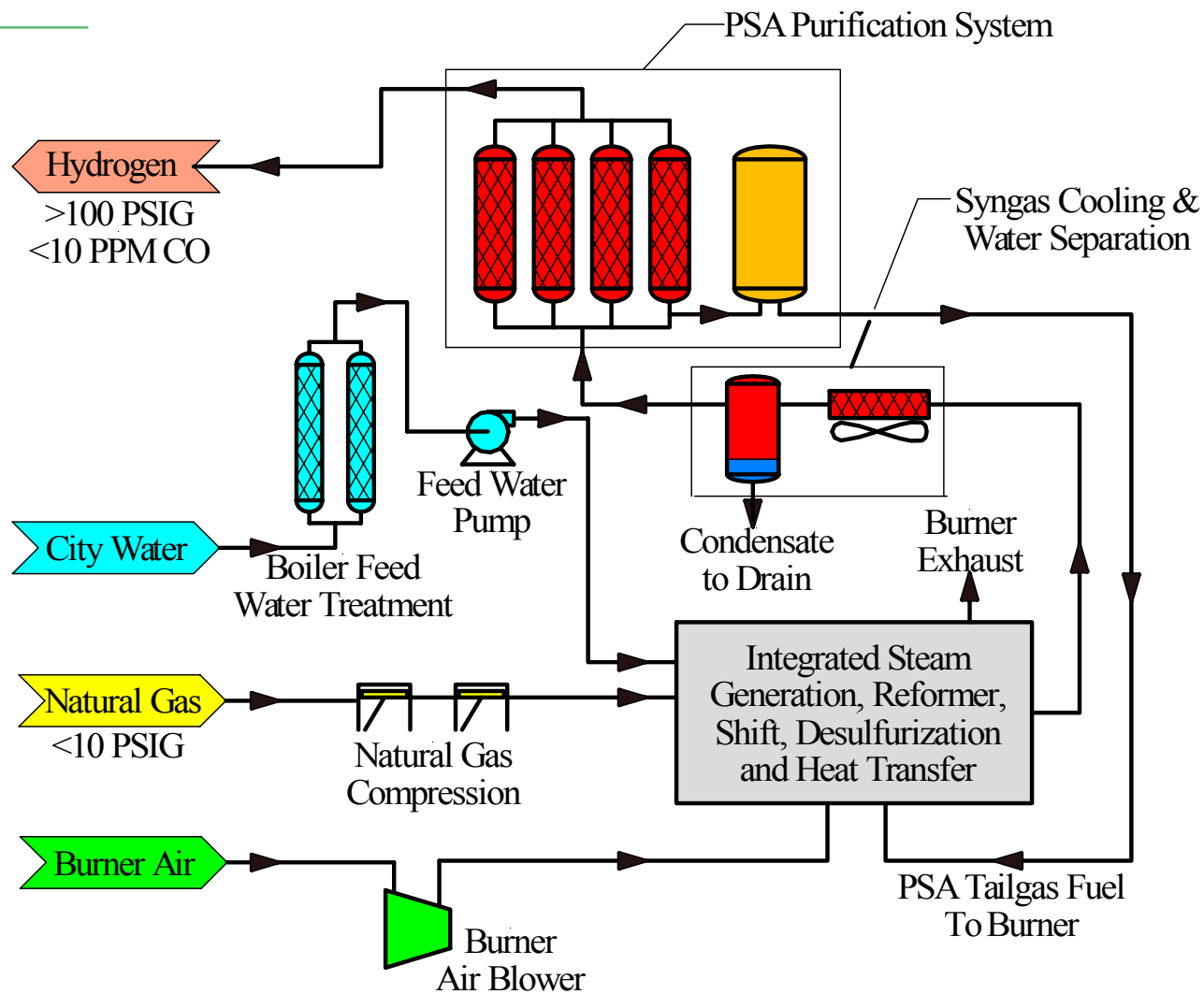

Overall System



- Safety
- Compact, Single Skid
- Easily Installed
- Welded Construction
- Highly Integrated

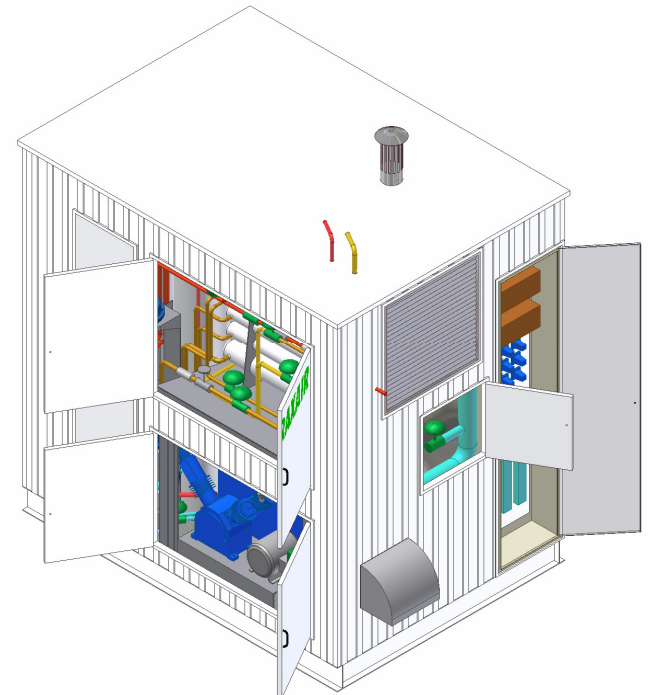
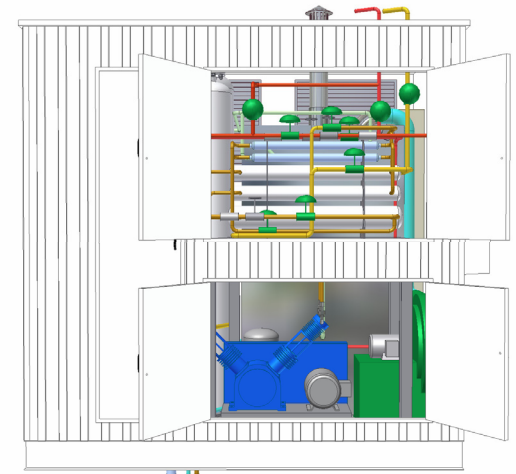
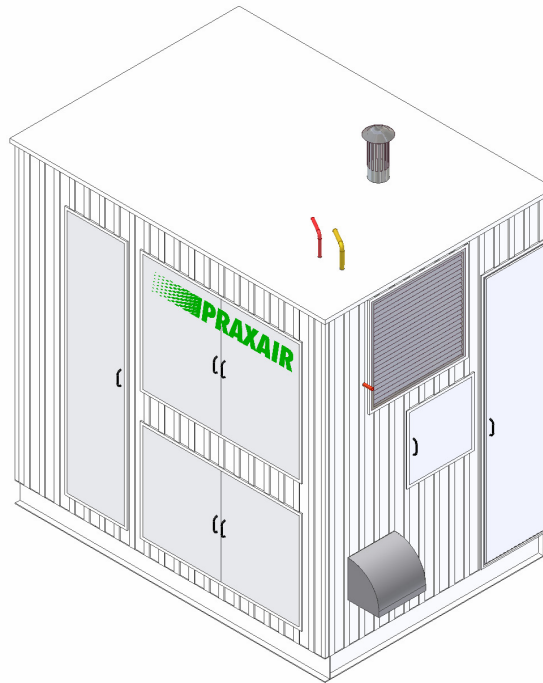
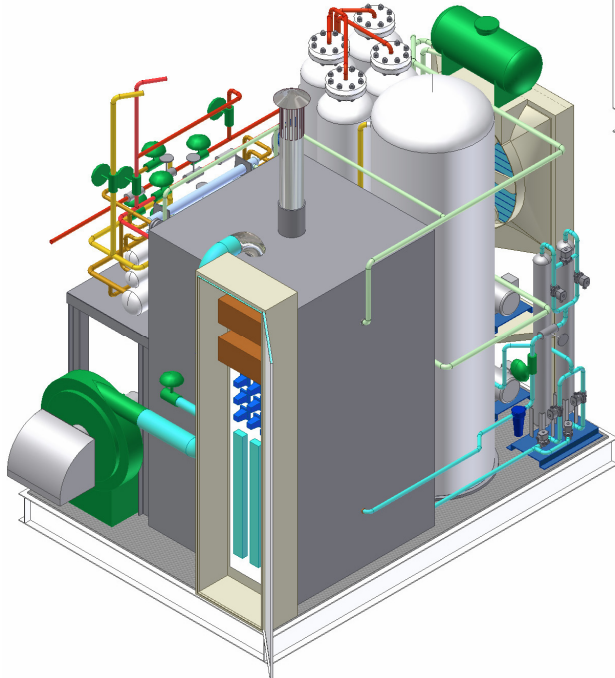

High Temperature Component



➤ Functions

- Natural Gas Pre-Heat
- Desulfurization
- Reforming
- Water-Gas Shift Reactor
- Steam Generation and Superheat
- Combustion
- Air/Exhaust/Process Heat Exchange
- Syngas Cooling

➤ Design

- DFMA
- Highly Integrated
- Welded Construction



LCHPP – Progress

- **High Temperature Component**
 - Prototype Design Complete
 - Computer Modeling Complete
 - Material Selection Complete
 - Patent Application Submitted

- **Testing**
 - Flow Testing With Full Size Mock-Up of Components
 - High Temp Test Rigs Designed and Fabricated
 - Testing Underway
 - System Configuration / Thermal Management
 - Catalyst
 - Burners
 - Auxiliary Components

Technical Accomplishments



➤ **Testing Prototype Components**

- Reactor Component Full Size Mock-Up Constructed
- Catalyst Configuration and Pressure Drop Testing Completed
- Scaled Reformer Testing Underway
- Full Size Test Rig Being Constructed
 - Reformer
 - Shift
 - Desulfurization
 - Heat Transfer
 - Burner
 - Steam Generation
- Safety Reviews of Test Rigs Completed

Accomplishments vs. DOE Barriers

- **A. Fuel Processor Capital Costs**
 - Highly Integrated System
 - “Off-The-Shelf” Components Used Wherever Possible
 - No Significant System Cost Increases from Last Year
 - Higher Material Costs
 - Part Count Reduced Slightly
 - Unit Capital Cost Comparable to Plants 20X Larger
 - Approaching Overall DOE Goals
- **B. Fuel Processor Manufacturing**
 - Extensive Use of DFMA Techniques (BDI)
 - Part Count
 - Assembly Time/Complexity
 - Review of Current Design Manufacturability (DMI)
 - Prototypes to Verify Results

Accomplishments vs. DOE Barriers - Continued

- **C. Operation and Maintenance (O&M)**
 - Control System Remote Capability
 - Easy Access to Critical Equipment
 - High Quality Components Used
 - Designed for 15 Year Life (7.5 Yr High Temp Component Life)
- **D. Feedstock and Water Issues**
 - Currently Natural Gas Reforming
 - Considerations Given to Alternative Feedstocks
 - Water Treatment and Steam System Being Tested
- **F. Control and Safety**
 - Risk Analysis Completed
 - Full HAZOP Review of System Will be Performed
 - All Applicable Standards Will Be Followed

LCHPP - System Cost Model Parameters



➤ Cost Model Assumptions

- Power - \$0.07 \$/kWh
- Natural Gas - \$4.50 \$/MMBtu, HHV
- Water - \$2.50 per 1,000 Gallon
- Capital Recovery Factor - 10% Return, 20 Yr Life
- Catalyst Life - 7.5 years (HT Component Refurbishment)
- On-Stream Factor - 90%
- Contingency - 10%
- M&R - 3% of Capital
- Site Labor
 - 15% @ 1 Unit ==> 2% @ 1000 Units

Technical Accomplishments / DOE Program Goals



H2 Cost vs Units Produced and H2 Flowrate

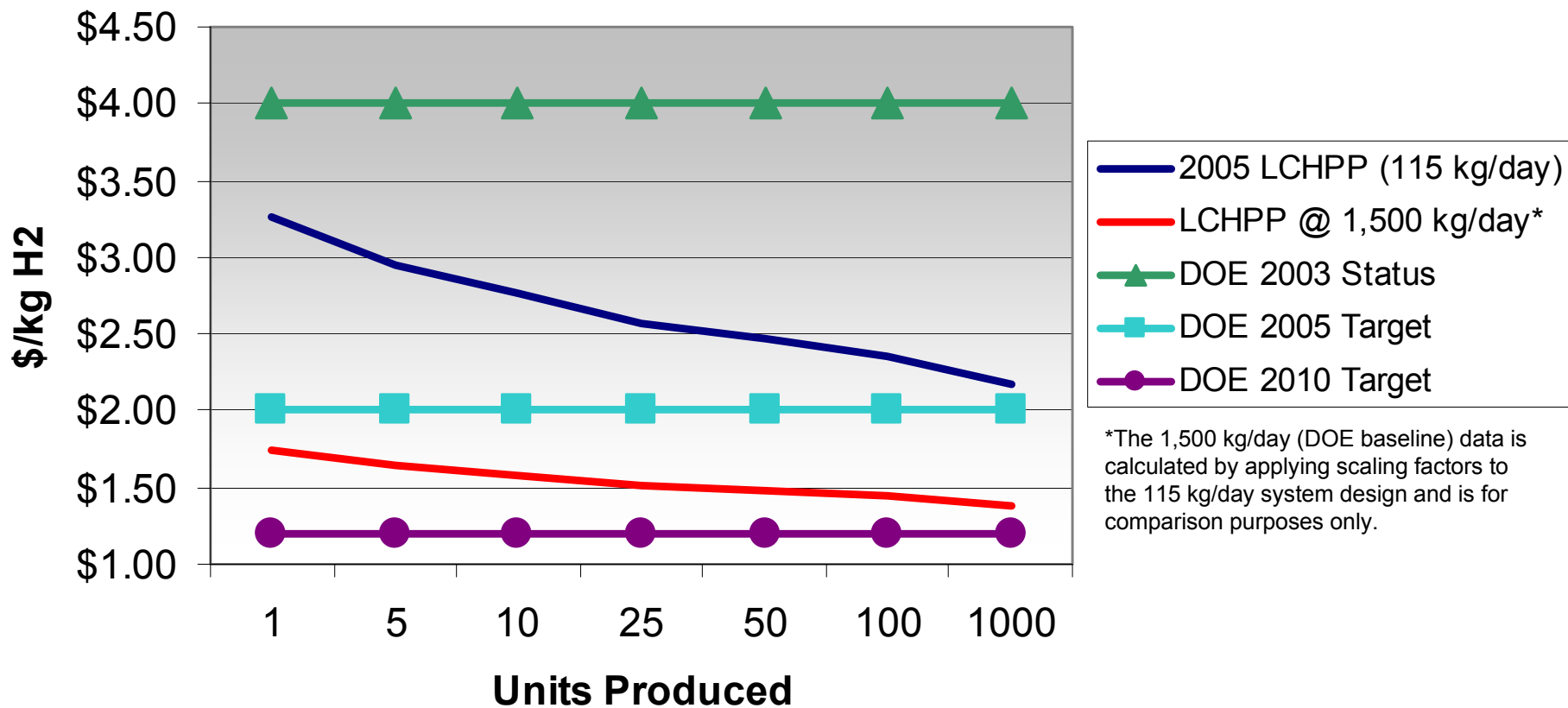

*The 1,500 kg/day (DOE baseline) data is calculated by applying scaling factors to the 115 kg/day system design and is for comparison purposes only.

2004 Reviewers' Comments



- **Project would benefit if compression, storage and dispensing included in scope of design**
 - The LAX fueling station project includes this scope and is being monitored and assessed for Integration potential into the LCHPP system.
- **What are the innovations that contribute to achievement of the DOE goals? Will it really be “low cost”?**
 - DFMA and other advanced packaging and design optimization have been shown to drastically lower the cost to produce a component or system while increasing its reliability. This system has been optimized by using the current lowest cost method of producing hydrogen (steam methane reforming) with these advanced design techniques. The result is a highly compact, optimized, reliable system that will set the benchmark for the producing small amounts of fuel cell grade hydrogen. Although this system is SMR based, many aspects of the optimized design could easily be integrated into other hydrogen production processes.
- **How much were the savings on the high temperature component?**
 - Cost were reduced by as much as 70% overall typical non-integrated systems.

LCHPP - Future Work

- **Remainder of FY 2005**
 - Testing of Components / Proof of Design
 - CFD Modeling
 - Component Testing
 - ◆ High Temp Component - Reformer, Shift, Desulfurization, Heat Transfer, Burner, Steam Generation
 - ◆ High Temperature Materials
 - ◆ Natural Gas Compression
 - ◆ Pressure Swing Adsorption (PSA) System
 - ◆ Auxiliary Components
 - Life Testing
 - Comparative Analysis with Supply Alternatives
 - Begin Design of Phase III Prototype of System

LCHPP - Future Work

- **FY 2006 – Phase III of Program**
 - Develop Prototype System – Components and Skid
 - Design, Fabrication and Assembly
 - Testing
 - ◆ Possible Integration into Fueling Station
 - ◆ Field Experience
 - ◆ Life Testing
 - Commercialize System
 - Economic Models
 - Manufacturing Plan
 - ◆ Production Design, Fabrication and Assembly Drawings
 - ◆ Design of Jigs and Fixtures
 - ◆ Supplier Selection

LCHPP - Conclusions



➤ **LCHPP Program**

- Low Cost Benchmark for Small Hydrogen Production
 - Projected Cost as low as \$2.15/kg @ 4.8 kg/hr
- Schedule Extended Per DOE Request
 - Completion of Phase II at End of 2005
 - Completion of Phase III at End of 2006
- Component Testing Underway
- Full Size Prototype Unit(s) Available in 2006
 - Life Testing of System
 - Placement at Fueling Station Demo Possible

Cooperative Efforts

- **Praxair**
 - Overall Lead
- **Boothroyd-Dewhurst**
 - System Optimization
 - Cost Reduction / Estimating
- **Diversified Manufacturing**
 - Manufacturing
 - Prototype Development
- **Computer Modeling**
 - Reformer / Shift Design
 - Burner Design
 - Heat Transfer
- **Catalyst Supplier**





Low Cost Hydrogen Production Platform

Cooperative Agreement: DE-FC36-01GO11004

Questions?

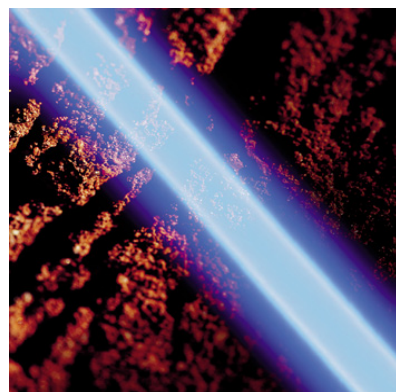
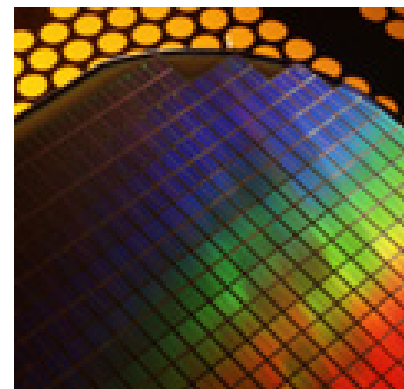

DOE Hydrogen Annual Review Meeting
May 23 - 26, 2005

Copyright © 2005 Praxair, Inc.

This paper was written with support of the U.S. Department of Energy under Contract No. DE-FC36-01GO11004. The Government reserves for itself and others acting on its behalf a royalty-free, nonexclusive, irrevocable, worldwide license for Governmental purposes to publish, distribute, translate, duplicate, exhibit and perform this copyrighted paper. This presentation does not contain any proprietary or confidential information.



LCHPP – Publications and Presentations



- **Society of Automotive Engineers (SAE)**
 - Paper and Presentation (October 2003)
 - DFMA Approach to Reducing the Cost of Hydrogen Produced from Natural Gas
- **The 2003 Hydrogen Production and Storage Forum (Washington, D.C.)**
 - Presentation and Roundtable Discussion (December 2003)
 - Using DFMA to Reduce the Cost of Hydrogen from Small Steam Methane Reformer Based Systems
- **ISO Technical Committee 197 - WG 9 (Member)**
 - ISO 16110-1 & 2: Hydrogen generators using fuel processing technologies

➤ **Hazards**

- Energy Release Within Components
 - Automated Purging of System Prior to Startup
 - Safe Operating Procedures Will be Implemented
 - Critical Operating Parameters (COPs) Implemented
- Venting of Flammable Gas
 - Normal Operation
 - ◆ Vent located Out of Top of Cabinet
 - ◆ Dispersion Calculations will be Completed
 - Leak of Flammable Gas Within Component
 - ◆ Forced Ventilation Will Keep Cabinet Below LEL Point
 - ◆ Minimal Inventory of Flammable Gas Within Component
 - ◆ Fuel Source Isolated with Fire-Safe Rated Valves

➤ **Design Safety**

- Risk Analysis Completed
- Full HAZOP Review of System Will be Performed
- All Applicable Standards Will Be Followed
 - NEC
 - NFPA
 - ISO
 - Praxair Design Standards and Procedures
- Member of ISO Technical Committee 197 - WG 9
 - ISO 16110-1 & 2: Hydrogen generators using fuel processing technologies
 - ◆ Part 1: Safety
 - ◆ Part 2: Performance